

## Operating Instructions

Pedestrian gate with swing doors

MHTM™ FlowMotion®

**mWing**

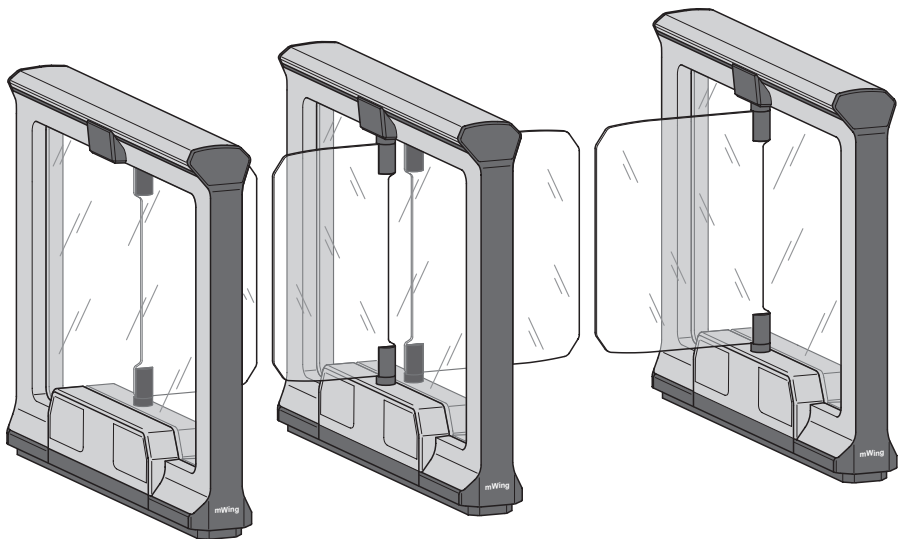

**MAGNETIC AUTOCONTROL GMBH**

Grienmatt 20  
D-79650 Schopfheim  
Germany

Phone +49 7622 695 5  
Fax +49 7622 695 802  
info@magnetic-germany.com  
www.magnetic-access.com

# Contents

<b>1</b>	<b>Notices on the document</b>	<b>7</b>
1.1	Purpose and contents of this operating instructions	7
1.2	Read and store the operating instructions	7
1.3	Non-compliance with the operating instructions	8
1.4	Symbols and illustrations used in these operating instructions	8
1.4.1	Warning notices and notices	8
<b>2</b>	<b>Safety</b>	<b>10</b>
2.1	Intended use	10
2.2	Changes and modifications	10
2.3	Target groups	11
2.3.1	Operator and his responsibilities	11
2.3.2	Personnel - activities and qualifications	12
2.4	Personal protective equipment	13
2.5	Symbols on the device	14
2.6	For your safety	14
2.7	To protect the environment	15
2.8	Emergency opening of the pedestrian gate	15
<b>3</b>	<b>Technical data</b>	<b>16</b>
3.1	Dimensions and design	16
3.1.1	mWing	16
3.2	Clearances and line configuration to be maintained	17
3.3	Electrical connection	18
3.4	Operating conditions	18
3.5	Emissions	18
3.6	Control unit MGCplus	19
<b>4</b>	<b>Design and function</b>	<b>20</b>
4.1	Design	20
4.2	Definitions	21
4.2.1	A-module	22
4.2.2	B-module	23
4.2.3	C-module	24
4.3	Function	25

---

<b>5</b>	<b>Receipt of goods, transport and storage</b>	<b>26</b>
5.1	Goods receiving department	26
5.2	Safety during transport	26
5.3	Transport	27
5.4	Storage	28
<hr/>		
<b>6</b>	<b>Unpacking, scope of delivery and identification</b>	<b>29</b>
6.1	Unpacking	29
6.2	Scope of delivery	30
6.3	Identification	32
6.3.1	Type plate	32
<hr/>		
<b>7</b>	<b>Installation and assembly</b>	<b>33</b>
7.1	Safety during installation and assembly	33
7.2	Mounting variants	34
7.3	Required steps	34
7.4	Setting up foundation and placing empty conduits	35
7.4.1	Requirements foundation	35
7.4.2	Requirements empty conduits	35
7.4.3	Setting up foundation and placing empty conduits	36
7.4.4	Foundation and empty conduit plan and reinforcement	37
7.5	Base plate and drilling template	41
7.6	Align the pedestrian gate	42
7.7	Mounting the mWing	42
7.7.1	Mounting variant "Direct mounting"	42
7.7.2	Mounting variant "Mount base plate"	45
7.7.3	Mounting variant "Glue base plate"	49
7.8	Assembly of the mWing	53
7.9	Mounting the swing doors	56
7.10	Dismounting and mounting the cover	57
7.11	Checking the assembly	58
<hr/>		
<b>8</b>	<b>Electrical connection</b>	<b>59</b>
8.1	Safety during electrical connection	59
8.2	Installing electrical protective devices	60
8.3	Connecting the mains cable	61

---

8.4	Connecting customer control lines	62
8.4.1	Connecting emergency opening contacts	63
8.5	Installing and connecting customer-access control devices	63
8.6	Checking the electrical connections	64
<b>9</b>	<b>Commissioning</b>	<b>65</b>
9.1	Safety during commissioning	65
9.2	Putting the pedestrian gate into operation	65
9.3	Switching the pedestrian gate on and off	65
9.4	Parameterising the pedestrian gate	67
<b>10</b>	<b>Test book</b>	<b>67</b>
<b>11</b>	<b>Operation</b>	<b>68</b>
<b>12</b>	<b>Cleaning and maintenance</b>	<b>69</b>
12.1	Cleaning the pedestrian gate	69
12.2	Maintenance schedule	69
<b>13</b>	<b>Corrective action</b>	<b>70</b>
<b>14</b>	<b>Spare parts and repair</b>	<b>70</b>
<b>15</b>	<b>Customer service</b>	<b>70</b>
<b>16</b>	<b>Decommissioning</b>	<b>71</b>
16.1	Safety during decommissioning	71
16.2	Take the pedestrian gate out of operation	71
<b>17</b>	<b>Disassembly and disposal</b>	<b>72</b>
17.1	Safety during disassembly and disposal	72
17.2	Dismantling and disposing of the pedestrian gate	72
<b>18</b>	<b>EU-Declaration of Conformity</b>	<b>73</b>
<b>Index</b>		<b>75</b>



## 1 Notices on the document

### 1.1 Purpose and contents of this operating instructions

These operating instructions provide all the information required for the product in the various phases of its life cycle.

These operating instructions contains the following information: Assembly and function, transport and storage, unpacking and delivery, installation and assembly, electrical connection, commissioning, operation, cleaning and maintenance, decommissioning, dismantling and disposal.



#### IMPORTANT!

For parameterisation see separate document "Description of MGC control unit for mWing (Doc.ID: 5817,0033)".

---

### 1.2 Read and store the operating instructions

Pre-requisite for safe working is the observance of all specified safety notes, warning notes and instructions. In addition, the local accident prevention regulations, general safety regulations and local environmental regulations applicable to the area of application of the product must be observed.

Carefully read these operating instructions before starting any work! The operating instructions are a product component and must be kept in direct proximity of the product, well accessible to the personnel at all times.

If the product is passed on to third parties, please also provide these operating instructions.

### 1.3 Non-compliance with the operating instructions

Magnetic declines all liability for personal injury and material damage caused by not observing the operating instructions.

This applies in particular to damage caused by:

- › Non-intended use
- › Use of non-qualified personnel
- › Use of non-approved components
- › Unauthorised modifications
- › Inappropriate assembly and installation
- › Improper operation
- › Defective or unperformed maintenance and repairs
- › Use of non-approved spare parts
- › Operation of a faulty product



### 1.4 Symbols and illustrations used in these operating instructions

#### 1.4.1 Warning notices and notices

Warning notes are characterised by pictograms in these operating instructions. A warning note starts with a signal word that expresses the extent of the hazard.

It is absolutely essential to observe the warning notes and to proceed with caution in order to prevent accidents as well as bodily injuries and property damage.

#### Warning Notes

 <b>DANGER</b>	
	The signal word DANGER points to an immediately dangerous situation, which leads to death or severe injuries if it is not avoided.

 <b>WARNING</b>	
	The signal word WARNING points to a potentially dangerous situation, which can lead to death or severe injuries if it is not avoided.



**CAUTION**

The signal word CAUTION points to a potentially dangerous situation, which can lead to minor injuries if it is not avoided.

**NOTICE**

The signal word NOTICE points to a potentially harmful situation, which leads to property damage if it is not avoided.

**Notes and recommendations****IMPORTANT!**

The signal word IMPORTANT highlights useful notes and recommendations as well as information for an efficient and trouble-free operation.

## 2 Safety

### 2.1 Intended use

The Magnetic pedestrian gate mWing is designed for the control of persons who wish to enter or leave a restricted area.

The pedestrian gate is intended for passage of persons who can pass the pedestrian gate safely, speedily and without any help. Separate access options are provided for persons who cannot pass the pedestrian gate safely or without any help, e.g. small children, the elderly or persons with impairments. Children under 8 years of age may only pass through the pedestrian gate under the supervision of an adult.

The pedestrian gate may only be mounted on non-flammable floors.

The pedestrian gate may only be operated within the temperature range indicated on the type plate.

#### Misapplications

Any other or further use is considered improper use. Magnetic is not liable for any resulting personal injury or damage to property.

For example, the following applications are considered to be contrary to regulations:

- › Unaccompanied use of the pedestrian gate by children under 8 years of age.
- › Use of the pedestrian gate by persons who cannot pass the pedestrian gate safely, quickly or without assistance.
- › Using the pedestrian gate without an enabled passage. This means that the swing door is forced to rotate.
- › Mounting the pedestrian gate on a flammable floor.

### 2.2 Changes and modifications

Changes or modifications to the product, attachments or components may result in unforeseen hazards. Before making any technical changes or modifications to the product or any of the components, written permission must be obtained from Magnetic.

## 2.3 Target groups

### 2.3.1 Operator and his responsibilities

The operator must comply with the statutory obligations regarding work safety. In addition to the safety instructions and warning notes in these operating instructions, the valid safety, accident prevention and environmental protection regulations must be observed.

In particular, the operator must:

- › determine additional danger in a danger analysis
- › implement the necessary behavioural requirements in work instructions for operation with the product at the operating location
- › regularly verify throughout the product time of use that the work instructions drawn up by him comply with the current state of the regulations
- › adapt the work instructions to any new provisions, standards and usage conditions - where required.
- › clearly regulate the responsibilities for all work on the product and with the product such as installation, commissioning, operation, cleaning, maintenance, etc.
- › that the personal protective equipment is worn
- › ensures that all employees who work with the product or on the product have read and understood the operating instructions.

Furthermore, the operator must train personnel regarding the use of the product at regular intervals and provide information on possible dangers.

Furthermore, the operator is responsible for:

- › the product is always in perfect technical condition.
- › the product is maintained at specified maintenance intervals
- › the product is only operated within the permitted temperature range.

The operator is also responsible that the danger area of the product cannot be accessed by any unauthorised persons under any circumstances.

### 2.3.2 Personnel – activities and qualifications

Only authorised, trained and sufficiently qualified personnel may work on and with the product. The personnel must know and understand the operating instructions and the required operating instructions.

Designation	Qualification
Transport equipment operator	<ul style="list-style-type: none"> <li>› Has professional experience as a transport equipment operator or warehouse and transport worker.</li> <li>› Has a valid driving licence for the required industrial truck, e.g. forklift.</li> <li>› Knows the necessary regulations.</li> <li>› Can assess the work assigned to her/him, recognises possible dangers and take suitable safety measures.</li> </ul>
Technician	<ul style="list-style-type: none"> <li>› Has completed training as a plant mechanic, plant fitter, assembly mechanic, assembly fitter or has a comparable technical education.</li> <li>› Has completed training as an electrical safety expert.</li> <li>› Has additional knowledge and experience.</li> <li>› Knows the associated technical terms and regulations.</li> <li>› Can assess the work assigned to her/him, recognises possible dangers and take suitable safety measures.</li> </ul>
Magnetic MHTM™ FlowMotion® service expert	<ul style="list-style-type: none"> <li>› Meets all requirements of the technician.</li> <li>› Trained and authorised by Magnetic.</li> </ul>
Operator	<ul style="list-style-type: none"> <li>› Trained by the operator.</li> </ul>

Table 1: Qualifications of personnel

Action	Transport equipment operator	Technician	Magnetic service expert	Operator
Transporting	X	X	–	–
Unpacking	X	X	X	–
Laying the foundation	–	X	–	–
Assembly	–	X	X	–
Electrically connect	–	X	X	–
Parameterise	–	–	X	–
Commissioning <sup>1)</sup>	–	–	X	–
Operating	–	X	X	X
Cleaning	–	X	X	X
Waiting	–	X	X	–
Rectify faults	–	X	X	–
Repairing	–	X	X	–
Decommissioning	–	X	X	–
Disassemble	–	X	X	–
Dispose	–	X	–	–

1) According to the supplied test book MHTM™ FlowMotion® mWing

Table 2: Activities and qualifications

## 2.4 Personal protective equipment

It is necessary to wear personal protective equipment when dealing with the product so as to minimise health hazards.

Before carrying out any work, properly dress in the necessary protective equipment such as work clothes, protective gloves and safety shoes and wear during work.

## 2.5 Symbols on the device

---



### **Warning of dangerous electrical voltage!**

The warning sign indicates hazardous areas with dangerous electrical voltage. Non-observance of the warning signs causes severe injuries or death. The work to be carried out may only be carried out by a qualified electrician or an electric safety expert.

This warning sign is fixed at the following point:

- › At the terminals, under the cover.
- 

## 2.6 For your safety

---



### **Mortal danger by electric voltage!**

Touching live parts can be lethal. Damaged insulation or damaged parts may be fatal.

- › If the insulation or any parts are damaged, switch off the power supply at once and initiate repair.
  - › Only qualified electricians or electrical safety experts may work on the electrical system.
  - › Switch off power supply and secure against re-activation before performing any work. Test for absence of voltage.
  - › Perform electrical installation in accordance with the applicable regulations.
  - › Install protective devices that are prescribed by national regulations, such as e.g. residual current circuit breakers. These protective devices must be provided by the customer.
  - › Observe the information on the type plate.
  - › Close all covers after work has been carried out.
  - › Keep moisture and dust away from live parts. Penetrating moisture and dust can lead to a short circuit.
  - › If the electrical connection is made during precipitation, e.g. rain or snow, prevent the penetration of moisture by means of suitable protective covers.
  - › During or after a lightning strike into the system, there is danger to life if the components are touched or during a stay in the immediate vicinity of the system. When installing outdoors, do not install and mount the pedestrian gate during thunderstorms.
-

## 2.7 To protect the environment

---



### **Improper disposal!**

Improper disposal can lead to damage to the environment.

- › Dispose of product in accordance with local and national laws and regulations.
  - › Sort resources and supply them to recycling.
- 

## 2.8 Emergency opening of the pedestrian gate

↗ Page 63, chapter 8.4.1.

### 3 Technical data

#### 3.1 Dimensions and design

##### 3.1.1 mWing

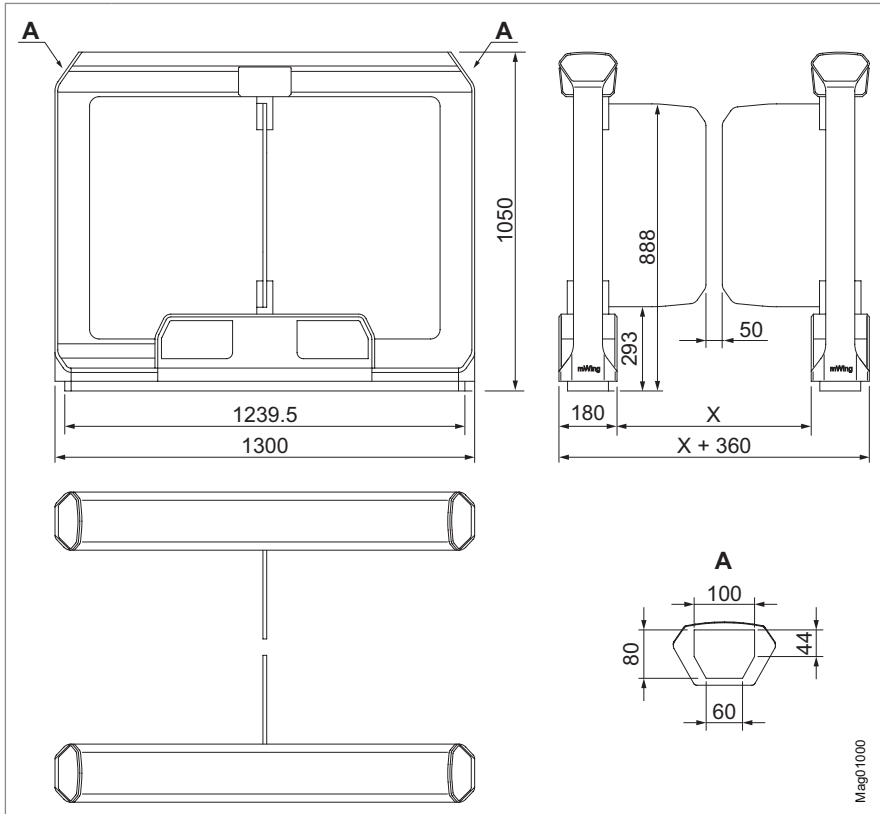

Fig. 1: Dimensions of the mWing (sizes in mm),  
X corresponds to the ordered passage width

A Installation space for reader without the option of the passage direction display, installation depth 40 mm



Designation	Value
Dimensions (length x width x height)	1300 mm x 290 mm x 1050 mm ↗ Page 16, Fig. 1.
Passage width	<ul style="list-style-type: none"> <li>› Standard variants: 600 mm or 900 mm</li> <li>› Special variants: 520 mm or 960 mm</li> </ul>
Weight	<ul style="list-style-type: none"> <li>› Pedestrian gate: Approx. 82 kg</li> <li>› Optional foundation frame: Approx. 10.6 kg</li> </ul>
Material	<ul style="list-style-type: none"> <li>› Housing: mDure</li> <li>› Optional foundation frame: Stainless steel</li> </ul>

Table 3: Dimensions and design – mWing

### 3.2 Clearances and line configuration to be maintained

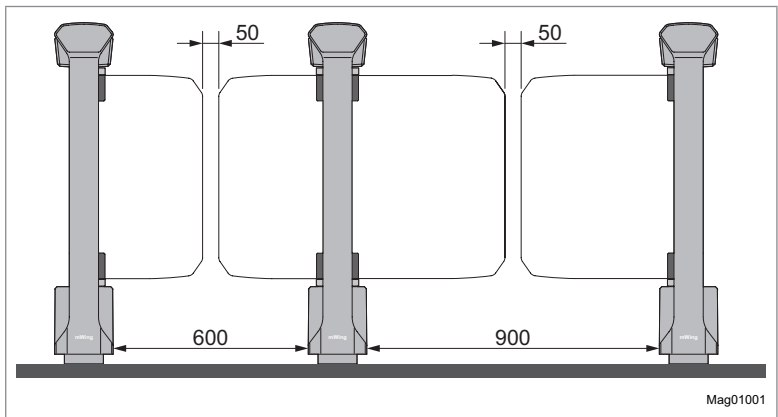

Fig. 2: Clearances and line configuration to be maintained. Minimum distance 50 mm

### 3.3 Electrical connection

Designation	Value
Power supply	100 to 240 V AC ± 10 %, 50 to 60 Hz
Current consumption at 240 V AC	1.0 A
Current consumption at 100 V AC	2.1 A
Max. performance	174 W
Duty cycle	100 %

Table 4: Electrical connection

### 3.4 Operating conditions

Designation	Value
Operating temperature range	-30 to +55 °C
Storage temperature range	-30 to +55 °C
Relative humidity	Max. 95 %, non-condensing
IP rating	IP 54

Table 5: Operating conditions

### 3.5 Emissions

Designation	Value
Airborne sound pressure level (LpA)	≤ 70 dB (A)

Table 6: Emissions

### 3.6 Control unit MGCplus

Designation		Value
Power supply		24 V DC
Control unit		max. 1 A max. 300 mA + current consumption of the different plug-in modules
Power consumption		max. 24 W: Max. 7.2 W + power consumption of the individual plug-in modules
Control unit safety		1 A T
Output terminal 2	Output voltage	24 V DC
	Max. output current	300 mA
Digital inputs	Number	8
	Input voltage	24 ± 10 % V DC
	Input current	< 10 mA per input
	Max. cable length <sup>1)</sup>	30 m
Digital outputs	Number	4 (open collector)
	Input voltage	24 ± 10 % V DC
	Input current	100 mA
	Max. cable length <sup>1)</sup>	30 m
Relay outputs	Number	3 closers + 3 changeovers, isolated
	Max. switching voltage	30 V AC / DC
	Switching current	10 mA to 1 A
	Max. cable length <sup>1)</sup>	30 m
Display		Graphics display, 128 x 65 Pixel
Number of slots for plug-in modules		5

1) Specification without optional overvoltage module. For line lengths exceeding 30 m, overvoltage modules must be installed in front of the terminal clamps.

Table 7: Control unit MGCplus

## 4 Design and function

### 4.1 Design

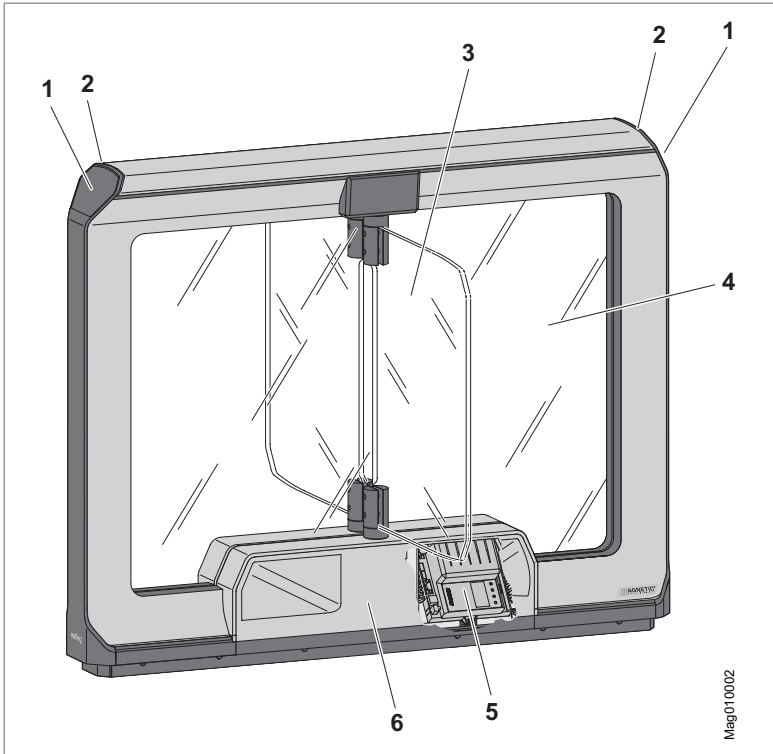

Fig. 3: Setup, here showing mWing

- 1 Room for access-control device provided by the customer, e.g. card reader
- 2 Space for GED (passage direction display)
- 3 Swing door e.g. glass wing
- 4 Inlay
- 5 Control unit MGCplus
- 6 Cover for control unit and drive blocking element

## 4.2 Definitions

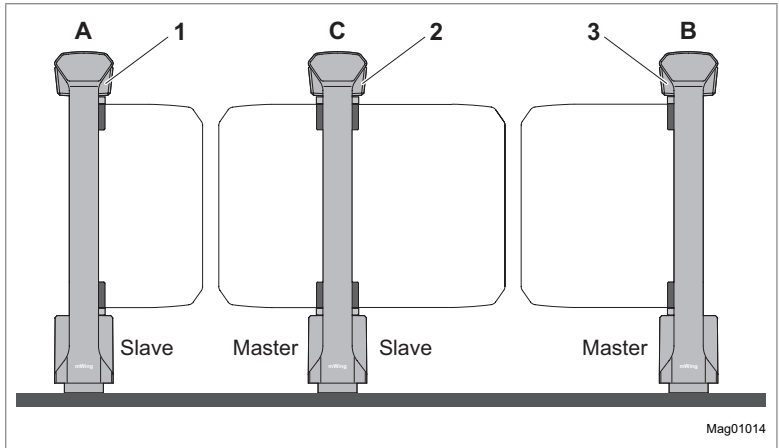

Fig. 4: Definitions

- 1 A-module: Slave-function, no control unit
- 2 C-module: Master function, the control unit is located on the master side
- 3 B-module: Slave and master function, the control unit is located on the master side

Every passage requires two modules. The swing doors of a passage are always controlled by the module with the master function.

### 4.2.1 A-module

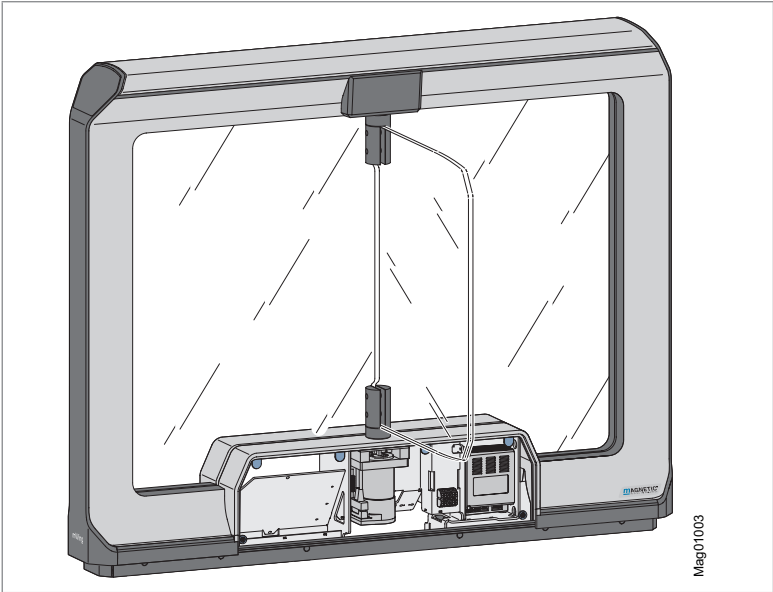

Fig. 5: A-module, shown without cover here the A-module performs the slave function.

## 4.2.2 B-module

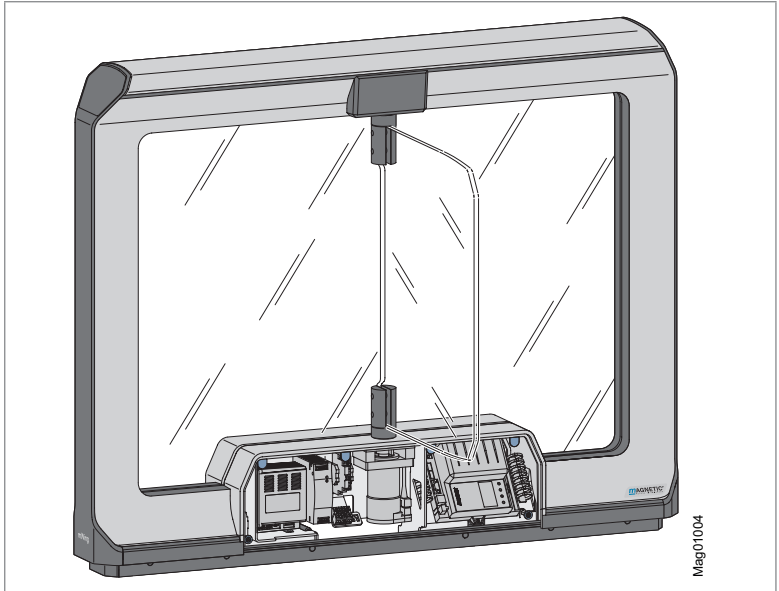

Fig. 6: B-module, shown without cover here  
The B-module performs the master function.

### 4.2.3 C-module

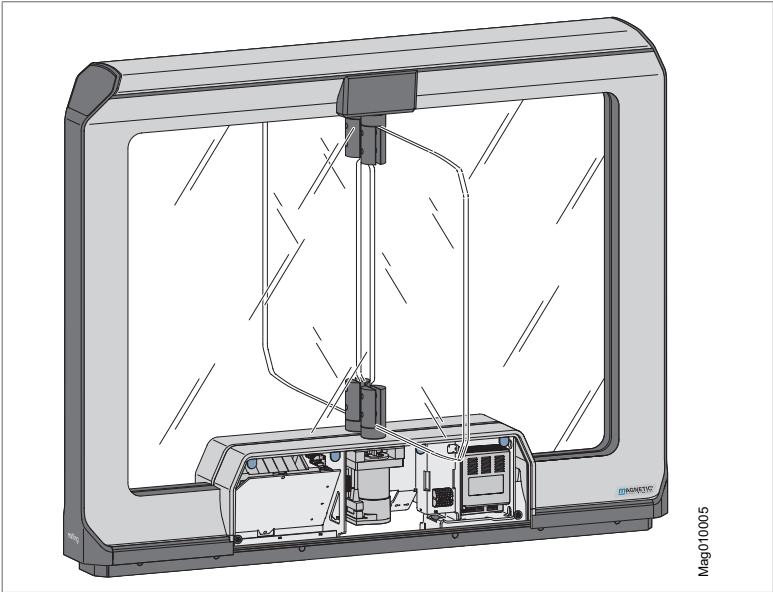

Fig. 7: C-module, shown without cover here  
The C-module performs the master and slave functions.



### 4.3 Function

The mWing Magnetic pedestrian gates with swing doors are used for a fast access control of persons, e.g. at the reception area of public buildings, hotels, companies, or museums. It can be used outdoors, e.g. in sports stadiums.

The modular system permits various line configurations. There are also some passage widths that permit access, e.g. with wheelchairs, strollers, etc.

The pedestrian gates can be operated in two directions. In multi-lane installations with high throughput rates, the entry and exit lanes can also be parameterised for operation in one direction. The gate end displays installed by default show the current mode via a green or red arrow.

In its normal state, the swing doors are closed. The swing doors only open after authorisation from an external command unit, such as a card reader.

Attempted cheating such as passage in the wrong direction, or a second person following without authorisation (tailgating) is recognised and activates the alarm system. Recognition takes place by several light barriers.

With MHTM drive technology, the swing doors can be blocked in any position, e.g. by hand. During a power outage, or if an emergency trips, the swing doors will be powered down and can be moved easily by hand.

The pedestrian gate is not intended for use by children aged eight and younger. They must take a separate passage.

A random function is integrated for checking persons or bags. If the random function reaches the random value of passages, the passage is blocked and a signal is given. Only after the operator, e.g. porter, has actuated an enable signal, the passage is enabled and the person can pass.

## **5 Receipt of goods, transport and storage**

### **5.1 Goods receiving department**

Immediately check the delivery after receipt for completeness and transport damages.

In the event of externally visible transport damage, proceed as follows:

- › Do not accept the delivery or only under reserve.
- › Note the extent of damage on the transport documents or on the delivery note of the carrier.
- › Lodge complaint.



#### **IMPORTANT!**

Lodge a complaint for each defect, as soon as it is recognised. Compensation claims can only be submitted within the valid complaint periods.

---

### **5.2 Safety during transport**



#### **Qualification of personnel**

- › Transport equipment operator
  - › Technician
  - › Magnetic MHTM™ FlowMotion® service expert
- ↗ Page 12, chapter 2.3.2.

#### **Personal protective equipment**

Wear the following personal protective equipment:

- › Work clothes
- › Protective gloves
- › Safety shoes.

 <b>WARNING</b>	
	<p><b>Lifting of heavy loads!</b></p> <p>The weight of heavy objects can severely injure a person's back or supportive system.</p> <ul style="list-style-type: none"><li>› Preferably transport the transported goods with suitable transport aids.</li><li>› Alternatively, the transported goods can be carried by two persons.</li><li>› Lift and deposit the transport goods with two persons.</li></ul>
<b>NOTICE</b>	
	<p><b>Improper transport!</b></p> <p>Improper transport can result in damage to the product.</p> <ul style="list-style-type: none"><li>› Observe the symbols on the packaging.</li><li>› Always load, transport and unload packages carefully.</li><li>› Observe dimensions.</li><li>› Do not remove packaging until immediately before assembly and at the final location of the product.</li></ul>

### 5.3 Transport

The recipient of the product is responsible for internal transport.

- › Transport and put down the load with a suitable forklift or lift truck.
- › The forklift forks or lift truck forks must reach completely under the transported goods. Observe the centre of gravity of the load.
- › Secure the load with sufficiently sized loops.

## **5.4 Storage**



Store packages or the product under the following conditions:

- › Store the delivery in its original packaging. Observe the symbols on the packaging.
- › Do not store outdoors.
- › Store dry and dust free.
- › Do not expose to aggressive media.
- › Protect against solar irradiation.
- › Avoid mechanical vibrations.
- › Storage temperature range: -30 to +55 °C
- › Relative humidity: max. 95 %, non-condensing

Check the general condition of all components and packaging regularly, if they are stored for longer periods than 3 months.

## 6 Unpacking, scope of delivery and identification

### 6.1 Unpacking

 <b>WARNING</b>	
	<p><b>Lifting of heavy loads!</b></p> <p>The weight of heavy objects can severely injure a person's back or supportive system.</p> <ul style="list-style-type: none"><li>› Preferably transport the transported goods with suitable transport aids.</li><li>› Alternatively, the transported goods can be carried by two persons.</li><li>› Lift and deposit the transport goods with two persons.</li></ul>

The individual components are packed according to the expected transport conditions.

Do not destroy the packaging and remove only directly before assembly. The packaging is designed to protect the individual components from transport damage, corrosion, etc.

1. Unpack product at final location.
2. Place the product vertically.
3. Report incomplete and faulty delivery to Magnetic.
4. Check the scope of delivery with the delivery note.
5. Separate material according to type and size and continue to use them after recycling. Observe national and regional laws and guidelines.

## 6.2 Scope of delivery

The following components are supplied as standard for each module:

- › 1 module (A-module, B-module or C-module)
- › 2 side parts (not installed)
- › 2 covers (not installed)
- › 2 strips (not installed)
- › 1 assembly tool
- › 1 drilling template
- › Documentation: Electrical circuit diagram, test book, these operating instructions and description "MGCplus control unit"

For options and attachments, see your order confirmation.

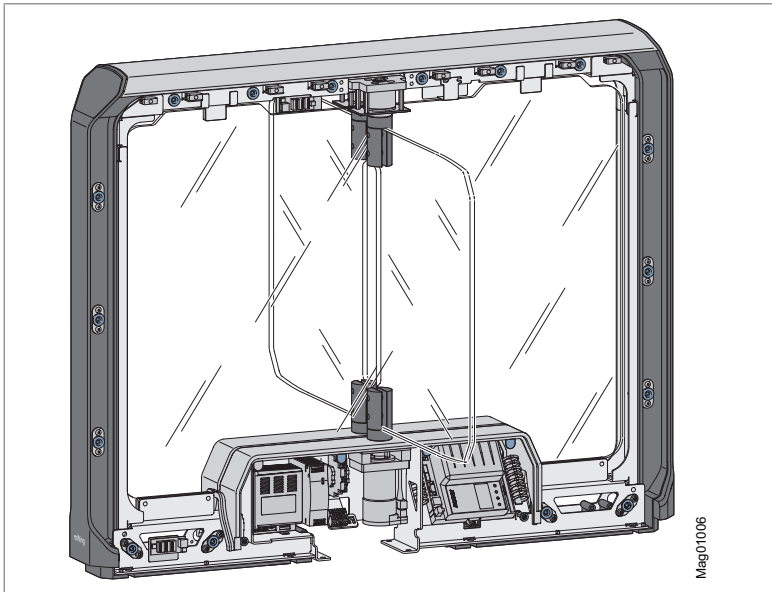

Fig. 8: Module ready for assembly without the loose parts of the scope of delivery, C-module shown here

**IMPORTANT!**

The swing doors are available in different heights. All figures show the swing doors in the standard height. Swing doors in the standard height are installed for delivery. Higher swing doors are delivered separately.

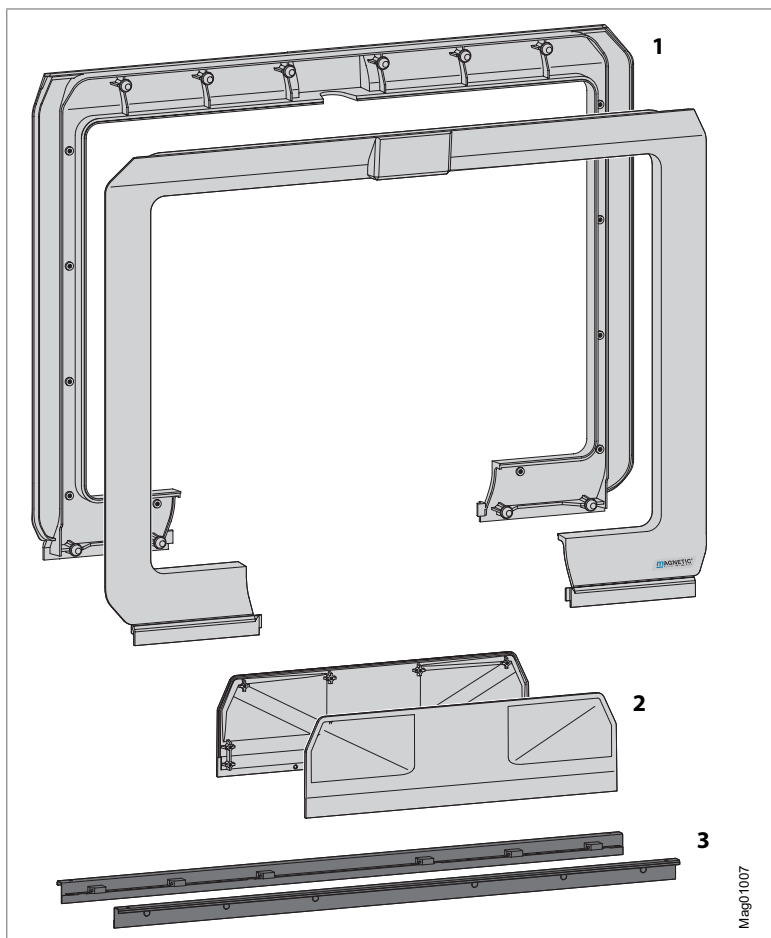

Fig. 9: Loose parts of the scope of delivery per module

- 1 Side parts (2)
- 2 Covers (2)
- 3 Strips (2)

### 6.3 Identification

#### 6.3.1 Type plate

The type plate is located under the cover to the right of the drive unit. The C-module has the type plate on the master side.

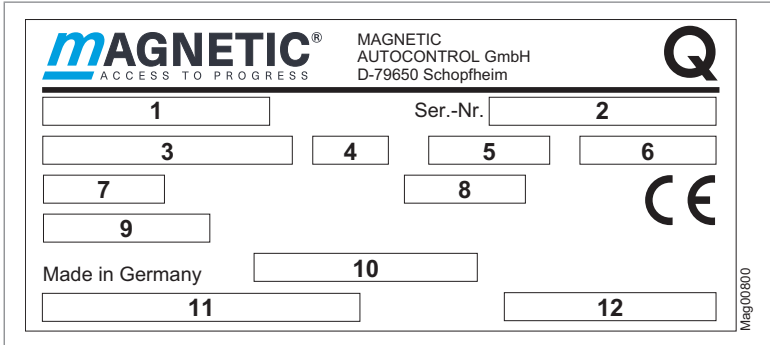

Fig. 10: Type plate

- 1 Product name
- 2 Serial number
- 3 Power supply
- 4 Frequency
- 5 Current consumption
- 6 Not used
- 7 IP rating
- 8 Duty cycle for operating mode S1 "Continuous operation"
- 9 Ambient temperature range
- 10 Date of manufacture, version, printing date of the type plate
- 11 Barcode of the product name
- 12 Bar code for serial number



## 7 Installation and assembly

### 7.1 Safety during installation and assembly



#### Qualification of personnel



- › Technician
  - › Magnetic MHTM™ FlowMotion® service expert
- Page 12, chapter 2.3.2.

#### Personal protective equipment

Wear the following personal protective equipment:

- › Work clothes
- › Protective gloves
- › Safety shoes.

 <b>WARNING</b>	
	<p><b>Improper attachment!</b></p> <p>Improper attachment can cause the pedestrian gate to tip over, causing bruising and serious injury.</p> <ul style="list-style-type: none"><li>› Install the pedestrian gate on the foundation according to the description.</li><li>› Observe and follow separate notices and instructions provided by the manufacturer of the attachment material.</li><li>› After assembly, check all bolts and nuts for tightness.</li></ul>

 <b>WARNING</b>	
	<p><b>Improper assembly on flammable ground!</b></p> <p>Installing the pedestrian gate on a flammable floor can promote the development of a fire and accelerate the spread of the fire. A fire and the resulting smoke can cause life-threatening injuries.</p> <ul style="list-style-type: none"><li>› Only install the pedestrian gate on a non-flammable floor.</li></ul>

## 7.2 Mounting variants

You may install the pedestrian gate as follows:

Mounting variant	Required material per module	Comments
Mount the pedestrian gate directly on a foundation.	<ul style="list-style-type: none"> <li>› Attachment set BSS100 for mounting the pedestrian gate directly on a foundation</li> </ul>	Use M8 x 30 screws. Do not use screws M8 x 16 for this mounting variant.
Mount base plate on foundation or unfinished floor. Mount the pedestrian gate on the finished floor using threaded rods.	<ul style="list-style-type: none"> <li>› Base plate FURA100</li> <li>› Attachment set BSSFURA100 for mounting the pedestrian gate using threaded rods</li> </ul>	The mounting material for the base plate must be provided by the customer.
Glue base plate to foundation or finished floor. Mount the pedestrian gate on the base plate.	<ul style="list-style-type: none"> <li>› Base plate FURA100</li> <li>› Attachment set BSKL100 for gluing the base plate</li> <li>› Attachment set BSS100 for mounting the pedestrian gate on the base plate <sup>1)</sup></li> </ul>	Use screws M8 x 16 from attachment set BSS100 for mounting the pedestrian gate. Do not use screws M8 x 30 for this mounting variant.

1) Foundation anchors and composite mortar are not required

Table 8: Mounting variants



### IMPORTANT!

You need to order the following attachments based on assembly version:

Base plate FURA100, attachment set BSS100, attachment set BSSFURA100, and attachment set BSKL100.

## 7.3 Required steps

The following work step must be carried out prior to assembly:

- › Set up foundation and placing empty conduits.   
 ↗ Page 35, chapter 7.4.

The following work steps must be carried out during assembly:

- › Unpack the pedestrian gate. ↗ Page 29, chapter 6.1.
- › Align the pedestrian gate.
- › Install the pedestrian gate. ↗ Page 53, chapter 7.8.
- › Connect the pedestrian gate electrically. ↗ Page 59, chapter 8.

## 7.4 Setting up foundation and placing empty conduits

### 7.4.1 Requirements foundation

The foundation must meet the following requirements:

- › Have sufficient load-carrying capacity
- › Concrete C20/25 or corresponding industrial floor
- › Attachment must be able to grip securely
- › Foundation cross section according to foundation and empty conduit plan
- › Non-slip surface
- › Horizontal and level.

↗ Foundation and empty conduit plan: Page 37, Fig. 11.

For outdoor assembly, the foundation must meet the following additional requirements:

- › Concrete C35/45 XD 3 XF2
- › Foundation depth: at least 800 mm, frost-proof. Adapt foundation depth to the local conditions.
- › Reinforcement mesh according to reinforcement plan

↗ Reinforcement plan: Page 38, Fig. 12.

### 7.4.2 Requirements empty conduits

Observe the following points for the empty conduits:

- › Place empty conduits according to the foundation plan.
- › Conduits have to be planned to a sufficient length.
- › Plan empty conduits required for access-control devices and other peripheral devices. The cabling for this is the responsibility of the customer.



#### IMPORTANT!

To ensure trouble-free operation, separate empty conduits must be installed for all mains cables and control lines.

---

### **7.4.3 Setting up foundation and placing empty conduits**

1. Excavate the foundation hole according to the foundation and empty conduit plan.
2. If installed outdoors, lay the reinforcement braid.
3. Place empty conduits according to the foundation and empty conduit plan in the foundation hole.
4. Close empty conduit to prevent water from entering.
5. Concrete the foundation.
6. Create smooth coating.
7. Let concrete cure.
8. Apply moisture protection for outdoor installation.

### 7.4.4 Foundation and empty conduit plan and reinforcement

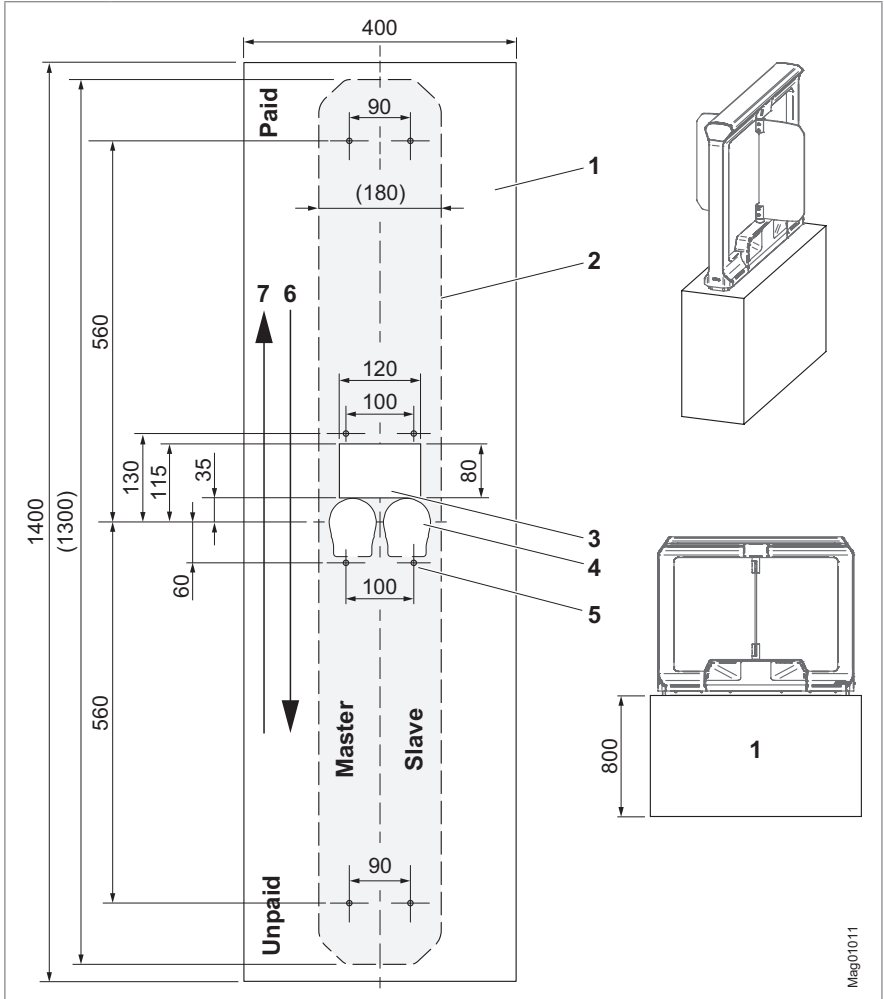

Fig. 11: Foundation and empty conduit plan (dimensions in mm)

- 1 Foundation, frost depth, outdoor area
- 2 Outline mWing
- 3 Feed-through for empty conduits
- 4 Position of the motors
- 5 Boreholes (8 x)
- 6 Passage direction 1 from "Paid" to "Unpaid"
- 7 Passage direction 2 from "Unpaid" to "Paid"

Mag01011

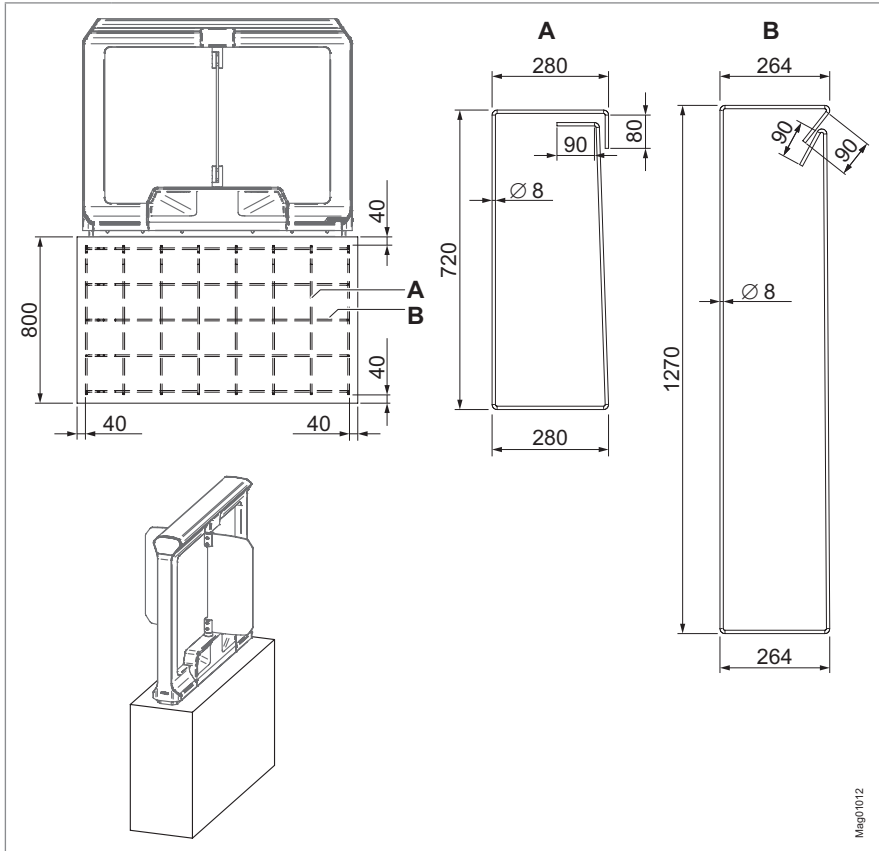

Fig. 12: Reinforcement plan (dimensions in mm)

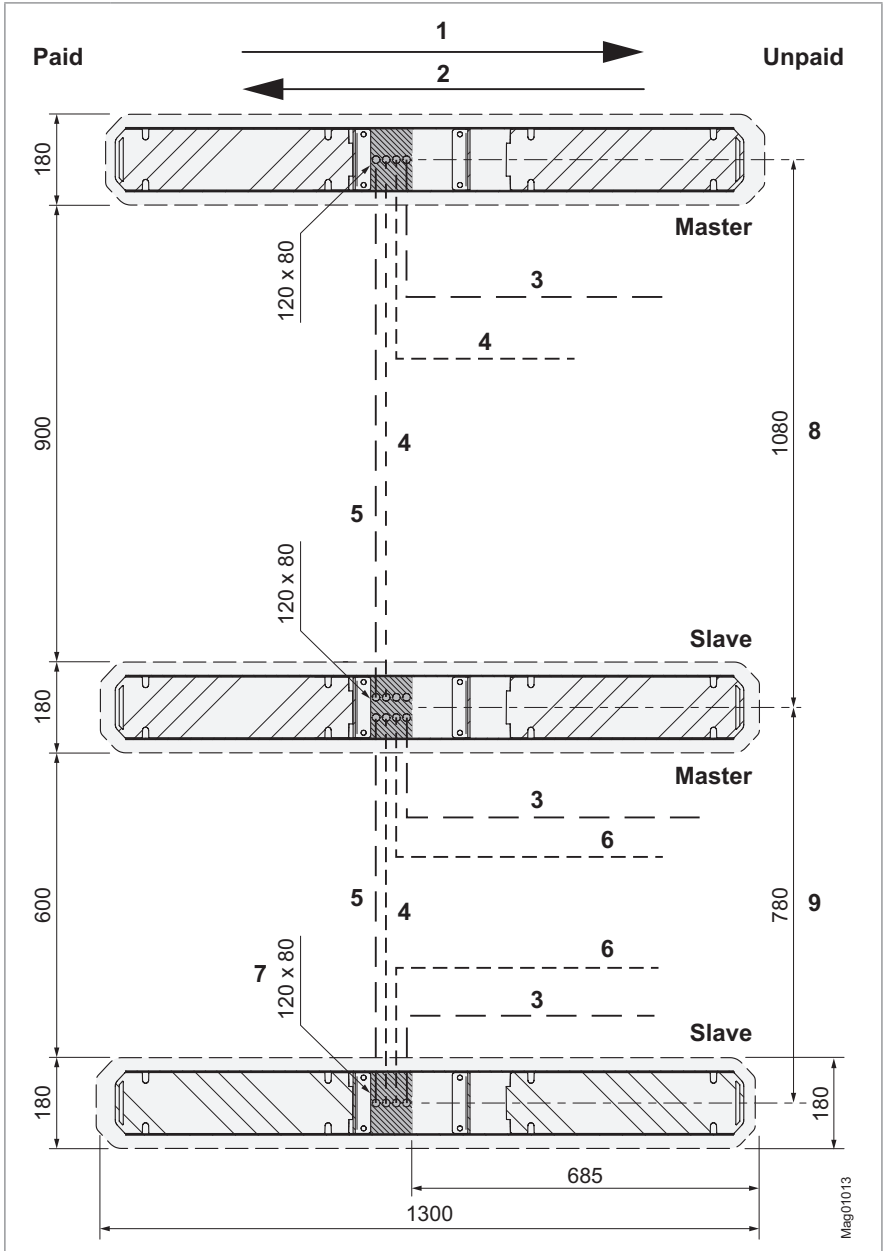

Fig. 13: Foundation and empty conduit plan (dimensions in mm)

**Key for empty conduit plan**

<b>Key number</b>	<b>Description</b>
1	Passage direction 1 from "Paid" to "Unpaid"
2	Passage direction 2 from "Unpaid" to "Paid"
3	Empty conduit for external data line
4	Empty conduit for 230 V
5	Minimal diameter $\varnothing$ 40 mm, empty conduit for supply, data and signal lines
6	Optional for empty conduit for 230 V
7	Area for conduits
8	Distance at a passage width of 900 mm
9	Distance at a passage width of 600 mm

Table 9: Key for empty conduit plan



## 7.5 Base plate and drilling template

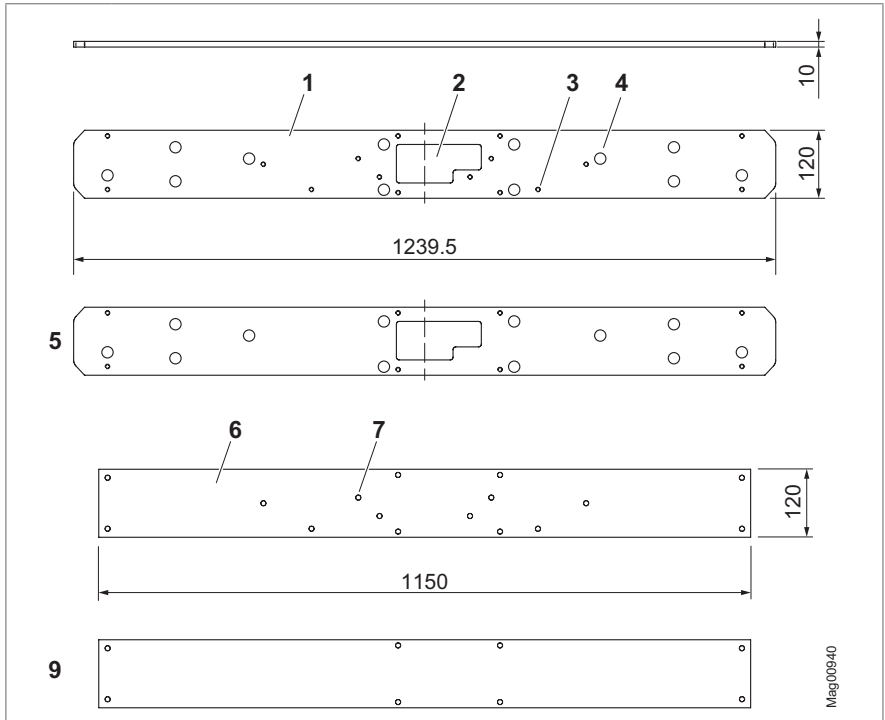

Fig. 14: Base plate and drilling template (dimensions in mm)

- 1 Base plate FURA100
- 2 Feed-through for empty conduits
- 3 Bores M8 for threaded rods or screws, see positions 6 and 9
- 4 Bores  $\varnothing 20$  mm for foundation anchors
- 5 Passage side
- 6 Base plate FURA100, only relevant positions for threaded rods or screws for mWing are shown
- 7 Drilling template, see position 6 and 9
- 8 Holes for threaded rods
- 9 Holes for threaded rods, only relevant positions for threaded rods for mWing are shown

## **7.6 Align the pedestrian gate**

When installing several pedestrian gates, align the pedestrian gates to the customer's specifications and to the on-site conditions, e.g. walls, tile joints and railings, using a laser or scale.

## **7.7 Mounting the mWing**

### **7.7.1 Mounting variant "Direct mounting"**

With this mounting variant, you mount the pedestrian gate directly on a foundation.

Required material (not enclosed):

- › Attachment set BSS100 for mounting the pedestrian gate directly on a foundation

#### **Prerequisites**

- › The foundation was built.
- › The empty conduits were laid.
- › The foundation has cured.

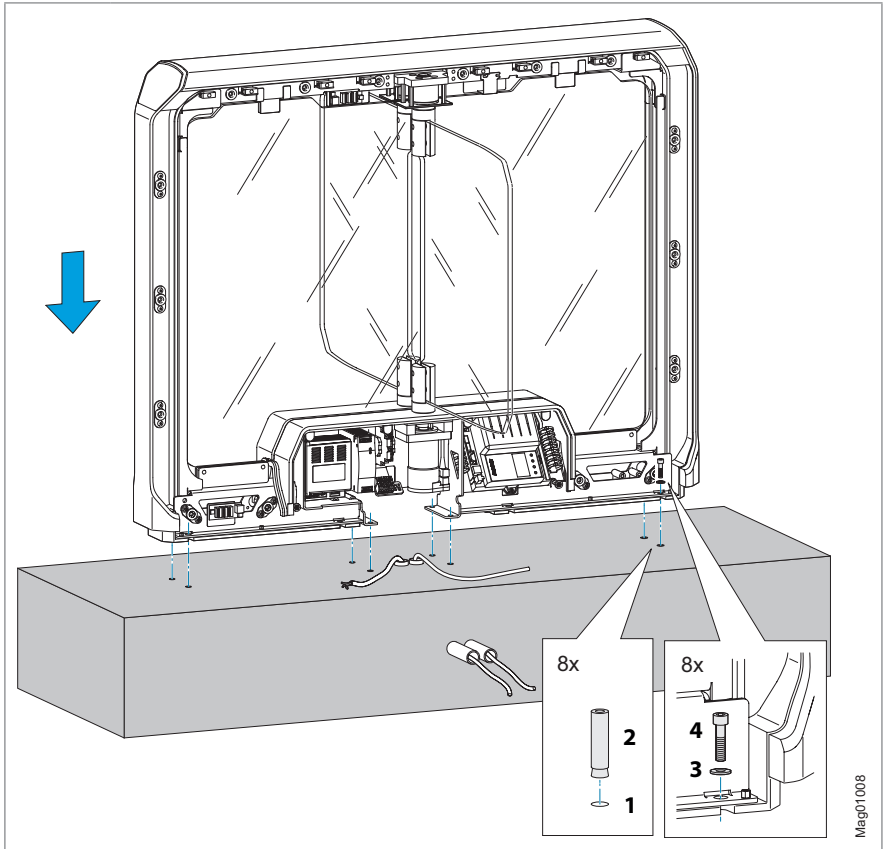

Fig. 15: Mounting version "direct mounting" – Mounting the pedestrian gate

- 1 Boreholes (8 x)
- 2 Sleeve with inner thread 12 x 90, M8, stainless steel (8 x)
- 3 Washer A 8.4 mm, stainless steel (4 x)
- 4 Screw M8 x 30, stainless steel



**IMPORTANT!**

Follow the separate notices and instructions for the composite mortar and foundation anchors.

➤ Foundation and empty conduit plan Page 37, Fig. 11.

1. Drill the boreholes for the sleeves with inner thread according to the foundation plan.

**NOTICE**

Wrong orientation of the pedestrian gate! The pedestrian gate is not symmetrically constructed. Align the pedestrian gate so that the passage side is on the correct side. Observe foundation plan.

2. Clean the boreholes with compressed air.
3. Inject composite mortar into the boreholes.
4. Turn in the sleeves with inner thread to the bottom of the boreholes by hand. The BSS100 attachment set contains mounting aids.
5. Wait for the curing time. Follow separate instructions.
6. Place pedestrian gate.
7. Place sleeve with inner thread, washers and hexagon head screws.



**WARNING**

Possible injuries due to falling pedestrian gate!

Use screws M8 x 30 from attachment set BSS100. Do not use the M8 x 16 screws.

8. Slightly tighten the screws.
9. Align the pedestrian gate.
10. Tighten the screws firmly.
11. If necessary, seal the housing with a silicone joint.
12. Arrange electrical connections. ↗ Page 59, chapter 8.
13. Mount strips, side parts, and cover. ↗ Page 53, chapter 7.8.

## 7.7.2 Mounting variant "Mount base plate"

With this type of installation, first mount the base plate on the foundation or on the unfinished floor. After completion of the finished floor, install the pedestrian gate on the finished floor using threaded rods.

Required material (not enclosed):

- › Base plate FURA100
- › Attachment set FURA100 for mounting the pedestrian gate
- › The mounting material for the base plate must be provided by the customer.

### Install and prepare the base plate before finishing the finished floor

#### Prerequisites

- › The foundation / raw floor was erected.
- › The empty conduits were laid.
- › The foundation / unfinished floor has hardened.

➤ Base plate and drilling template: Page 41, Fig. 14.

1. Mount the base plate on the foundation or unfinished floor.

#### NOTICE

Wrong orientation of the pedestrian gate! The pedestrian gate is not symmetrically constructed. Align the pedestrian gate so that the passage side is on the correct side. Note figure base plate.

2. Screw the threaded rods into the base plate.

#### NOTICE

Incorrect positioning of the threaded rods! Note figure base plate.

3. Fix threaded rods with nuts.
4. Mount the other nuts slightly above the planned finished floor height on the threaded rods.
5. Place the drilling template on the threaded rods.

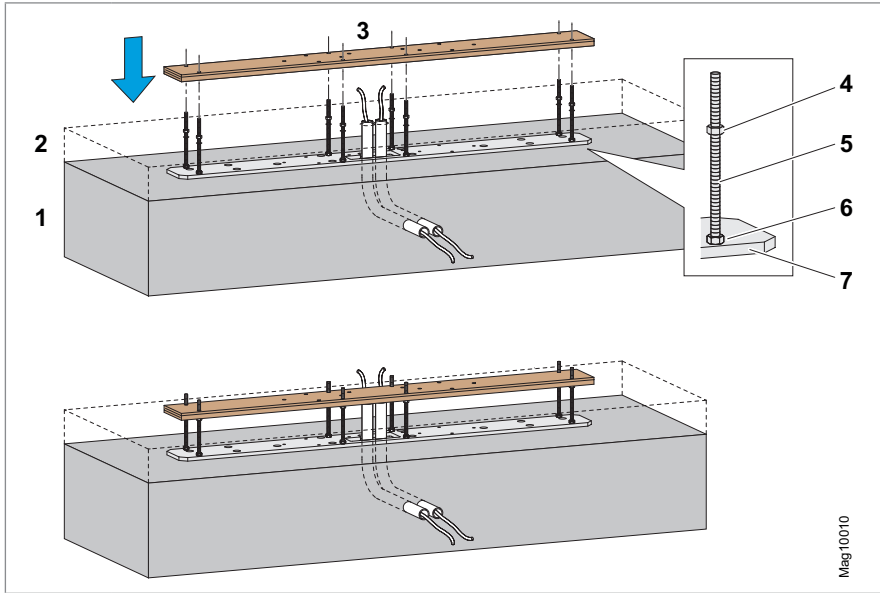

Mag10010

Fig. 16: Mounting and preparing the base plate

- 1 Foundation / raw floor
- 2 Planned finished floor
- 3 Drilling template
- 4 Nut M8, slightly above the planned finished floor
- 5 Threaded rods M8 x 210, stainless steel
- 6 Nut M8
- 7 Base plate

## Mounting the pedestrian gate after completion of the finished floor

### Prerequisites

- › The finished floor is finished.

1. Remove the drilling template and nuts from the threaded rods.

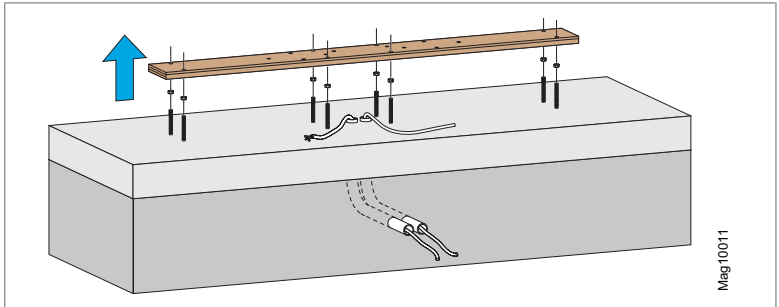

Fig. 17: Remove drilling template and nuts

2. Flex off threaded rods 20 mm above the finished floor.

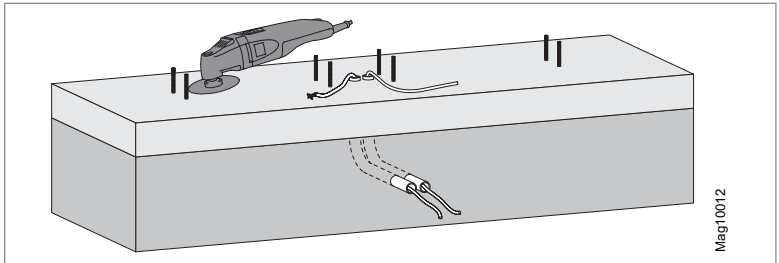

Fig. 18: Flexing off threaded rods

3. Place the pedestrian gate on the threaded rods. ↗ Page 48, Fig. 19.
4. Mount the pedestrian gate with screws.
5. Slightly tighten the screws.
6. Align the pedestrian gate.
7. Tighten screws to 10 Nm.
8. If necessary, seal the housing with a silicone joint.
9. Arrange electrical connections. ↗ Page 59, chapter 8.
10. Mount strips, side parts, and cover. ↗ Page 53, chapter 7.8.

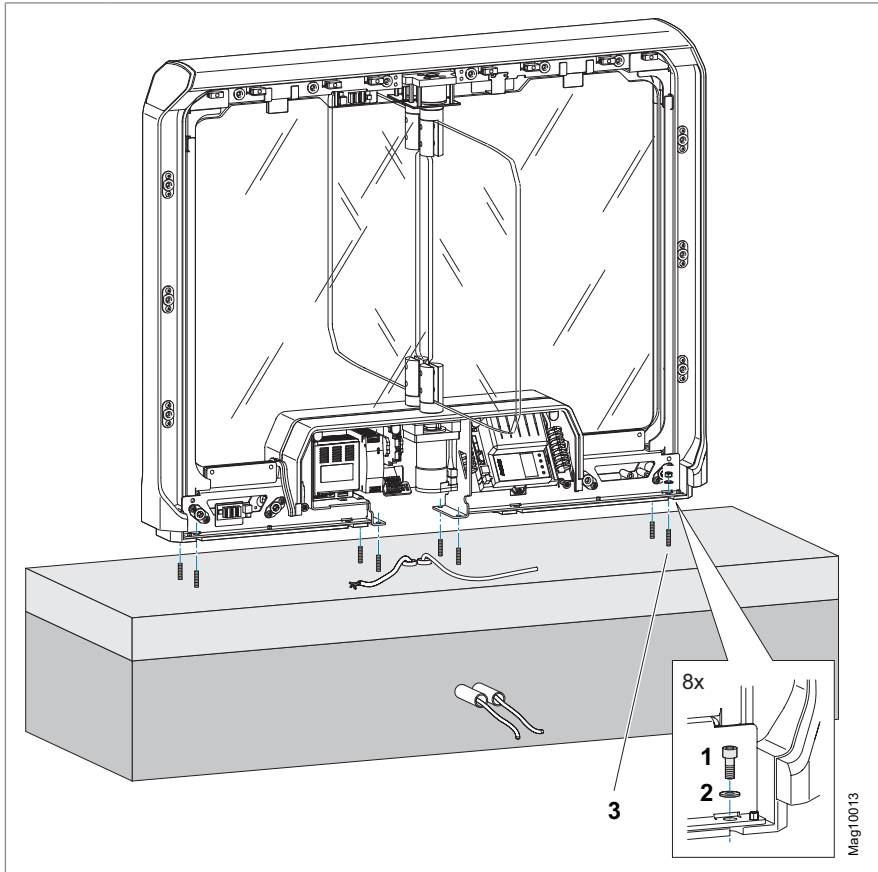

Fig. 19: Mounting version "base plate mounting" – Mounting the pedestrian gate

- 1 Nut M8 (8 x)
- 2 Washer A 8.4 mm, stainless steel (4 x)
- 3 Threaded rods M8 x 210, stainless steel, (8 x)



### 7.7.3 Mounting variant "Glue base plate"

With this type of installation, you first glue the base plate onto the foundation or the finished floor. Then mount the pedestrian gate on the base plate.

Required material (not enclosed):

- › Base plate FURA100
- › Attachment set BSKL100 for gluing the base plate
- › Attachment set BSS100 for mounting the pedestrian gate on the base plate (foundation anchors and composite mortar are not required)

#### Prerequisites

- › The foundation / finished floor was erected.
- › The empty conduits were laid.
- › The foundation / finished floor has hardened.



#### IMPORTANT!

Follow the separate instructions and packaging labels for the surface cleaner, construction adhesive and remover.

The floor must be free of paint and varnish.

---

↗ Base plate and drilling template: Page 41, Fig. 14

1. Place and align base plate.

**NOTICE**

Wrong orientation of the pedestrian gate! The pedestrian gate is not symmetrically constructed. Align the pedestrian gate so that the passage side is on the correct side. Note figure base plate.

2. Draw the outline of the base plate on the floor. Make sure that the markings are either washable or invisible.
3. Put the base plate aside. The underside must face upwards.
4. Clean the floor with the "HaftClean" surface cleaner.
5. Clean the underside of the base plate with the surface cleaner "HaftClean Metall".
6. Apply construction adhesive "Klebt + D Dicht Power" to the floor in the form of a beat within the marking. Apply less construction adhesive towards the edge.



Fig. 20: Apply construction adhesive

7. Immediately place the base plate on the construction adhesive. Observe markings.

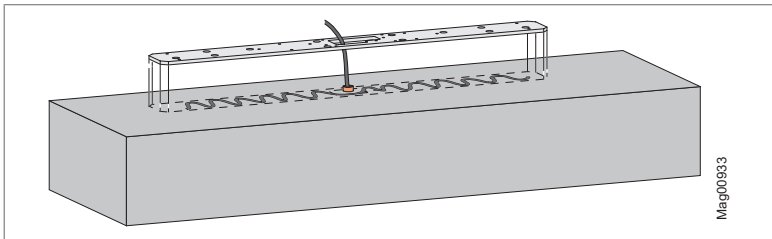

Fig. 21: Place base plate

8. Press the base plate on well immediately. If the base plate stands out due to unevenness of the floor, weight the base plate.

9. Remove excess construction adhesive as soon as possible with "Klebt + Dichtet Entferner". If the construction adhesive has already cured, remove excess construction adhesive with a suitable tool. When selecting the tool, consider the material of the base.
10. Wait for the curing time.
11. Place the pedestrian gate on the base plate. ↗ Page 52, Fig. 22.
12. Place washers and hexagonal screws.

**NOTICE**

Possible damage to the finished floor!

Use screws M8 x 16 from attachment set BSS100. Do not use the M8 x 30 screws.

13. Slightly tighten the screws.
14. Align the pedestrian gate.
15. Tighten the screws firmly.
16. If necessary, seal the base plate laterally with a silicone joint.
17. Arrange electrical connections. ↗ Page 59, chapter 8.
18. Mount strips, side parts, and cover. ↗ Page 53, chapter 7.8.

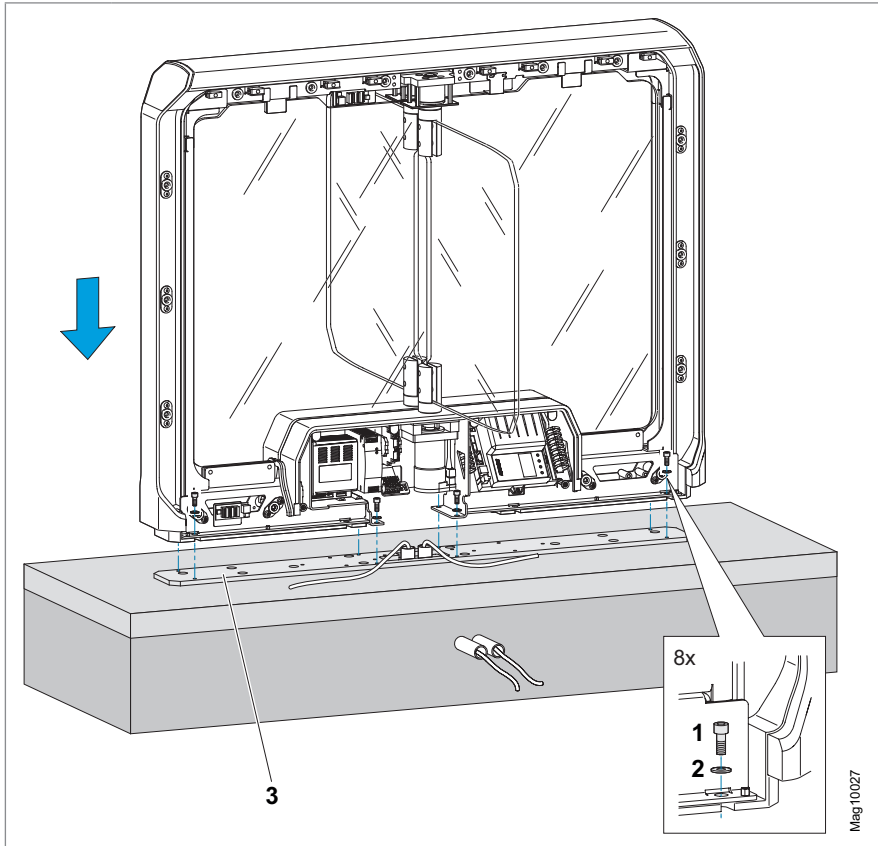

Fig. 22: Mounting version "gluing plate mounting" – Mounting the pedestrian gate

- 1 Screw M8 x 16, stainless steel, (8 x)
- 2 Washer A 8.4 mm, stainless steel (4 x)
- 3 Base plate

## 7.8 Assembly of the mWing

### Prerequisites

- › The pedestrian gate is mounted on the floor.

Covers, side parts, and lower strips are not assembled on delivery.

The swing doors are available in different heights. Swing doors in the standard height are installed for delivery. Higher swing doors are delivered separately.

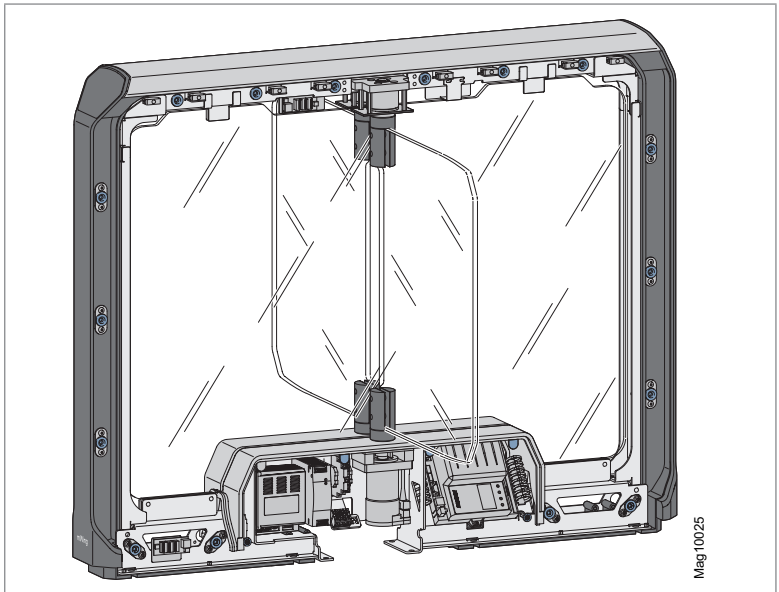

Fig. 23: Pedestrian gate in the delivery status

1. Arrange electrical connections. ↗ Page 59, chapter 8.
2. Mount the strips.

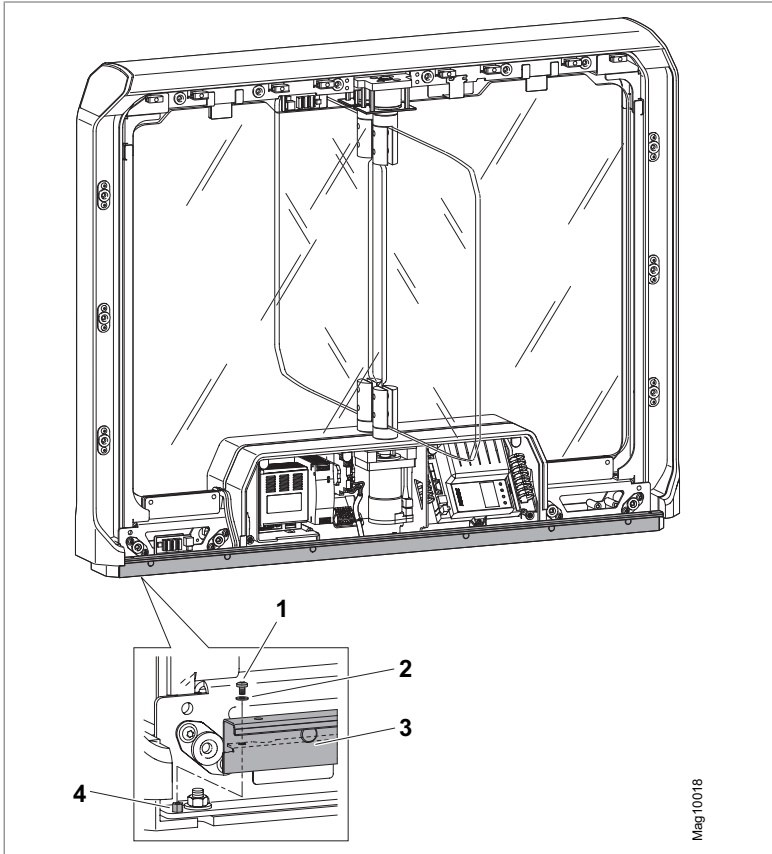

Fig. 24: Mounting the strips

- 1 Screw
- 2 Washer
- 3 Strip
- 4 Thread

3. Assemble side part. A click sound is heard each time it clicks into place.

**NOTICE**

Do not trap any cables when closing the side parts.

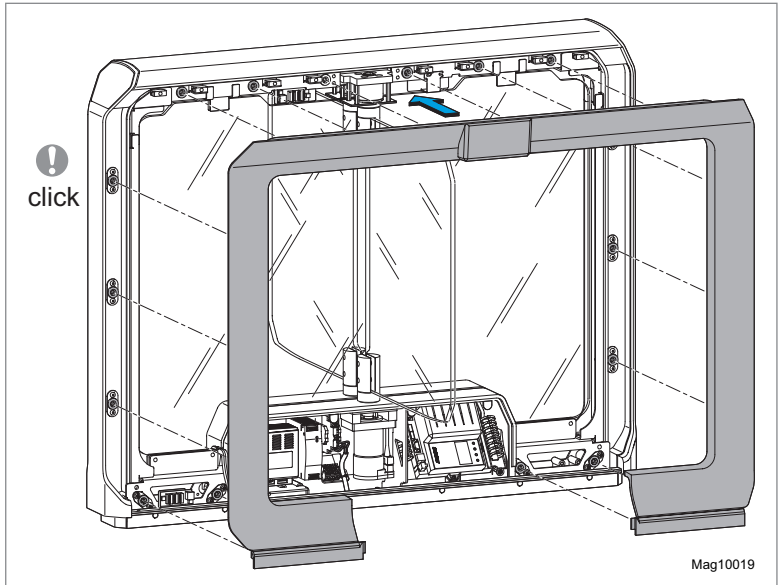

Fig. 25: Assembly of the side part

4. Assemble cover. The cover is held on by magnets.

**⚠ CAUTION**

Danger of crushing! Hold the cover with both hands only on the side. Do not hold the cover at the top or bottom edge.

- › Attach the cover.
- › Tilt the cover backwards until the magnets close the cover.

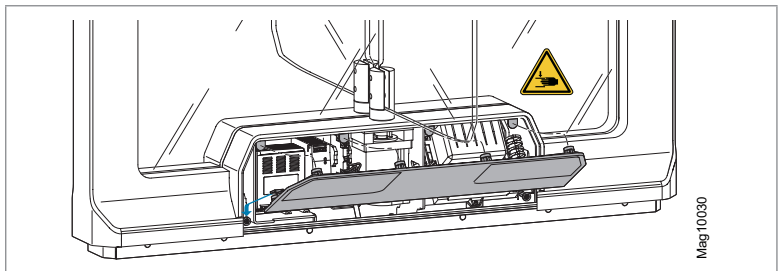

Fig. 26: Assembly of the cover

## 7.9 Mounting the swing doors



**IMPORTANT!**

The swing doors are available in different heights. All figures show the swing doors in the standard height. Swing doors in the standard height are installed for delivery. Higher swing doors are delivered separately.

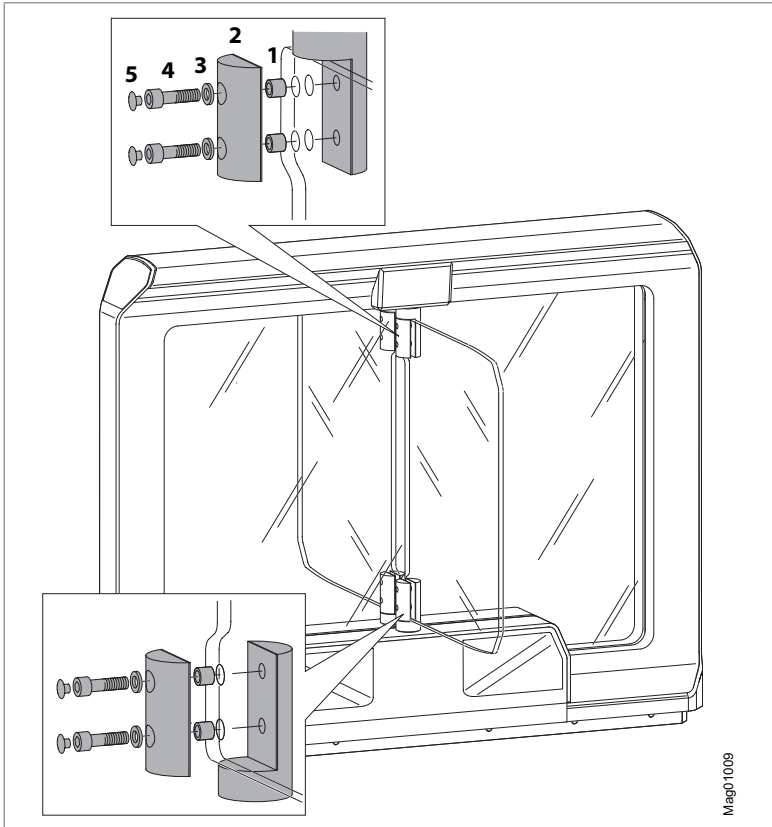

Fig. 27: Mounting the swing doors, e.g. glass wings

- 1 Sleeve
- 2 Attachment
- 3 Washer
- 4 Screw
- 5 Screw cover



1. Stick enclosed label from the document set onto the glass wing. The label makes it easier to see the glass wing. You can also use your own labels instead of the enclosed ones, e.g. with your company logo.
2. A label is stuck to the swing door. The label gives values for S, T and C. These values are needed for parameterisation.
3. Place the glass wings before the attachment points.
4. Screw on the glass wings at the top and bottom.

## 7.10 Dismounting and mounting the cover

For the following activities, for example, you must disassemble the cover:

- › Switch the pedestrian gate on and off.
- › Parameterise the control unit MGCplus.

The cover is held on by magnets.

### Disassembly of the cover

1. Place the supplied tool near the magnets.
2. Lever the cover forward with the tools.
3. Disconnect the cover.

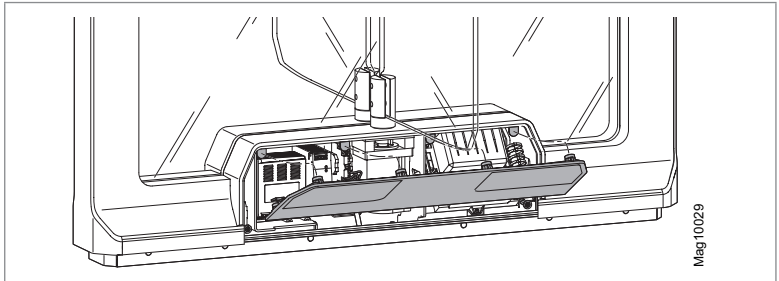

Fig. 28: Installing the cover

**Assembly of the cover**

1. Attach the cover.

**⚠ CAUTION**

Danger of crushing! Hold the cover with both hands only on the side. Do not hold the cover at the top or bottom edge.

2. Tilt the cover backwards until the magnets close the cover.

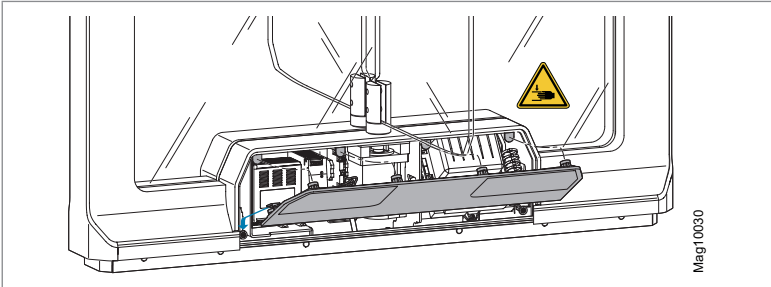

Fig. 29: Assembly of the cover

**7.11 Checking the assembly**

After assembly, check the following points:

- › Are all screws and nuts tightened?
- › Have all pedestrian gate covers been properly assembled?

## 8 Electrical connection

### 8.1 Safety during electrical connection



#### Qualification of personnel



- › Technician
  - › Magnetic MHTM™ FlowMotion® service expert
- Page 12, chapter 2.3.2.

#### Personal protective equipment

Wear the following personal protective equipment:

- › Work clothes
- › Protective gloves
- › Safety shoes.

 <b>DANGER</b>	
	<p><b>Electric voltage!</b></p> <p>Touching live parts can be lethal. Damaged insulation or damaged parts may be fatal.</p> <ul style="list-style-type: none"> <li>› Only qualified electricians or electrical safety experts may work on the electrical system.</li> <li>› Switch off power supply and secure against re-activation before performing any work. Test for absence of voltage.</li> <li>› Keep moisture and dust away from live parts. Penetrating moisture or dust can lead to a short circuit.</li> <li>› If the electrical connection is established at precipitation, e.g. rain or snow, penetration of moisture must be prevented by suitable measures, such as a protective cover.</li> <li>› Install protective devices that are prescribed by national regulations, such as e.g. residual current circuit breakers. These protective devices must be provided by the customer.</li> <li>› Observe the information on the type plate.</li> <li>› Close all covers after work has been carried out.</li> </ul>

 <b>DANGER</b>	
	<p><b>Mortal danger from lightning and electrical voltage!</b></p> <p>During or after a lightning strike into the system, there is danger to life if the components are touched or during a stay in the immediate vicinity of the system.</p> <ul style="list-style-type: none"><li>› When installing outdoors, do not install and mount the pedestrian gate during thunderstorms.</li><li>› Protect yourself in buildings or vehicles.</li></ul>

<b>NOTICE</b>	
	<p><b>Electromagnetic interference!</b></p> <p>The pedestrian gate is approved for industrial, residential, commercial and business use. Operation in other electro-magnetic environmental conditions may cause interference or malfunctions.</p> <ul style="list-style-type: none"><li>› Place control lines and mains cables into separate conduits.</li><li>› Customer access-control devices, signal transmitters and receivers must be EMC-tested and comply with the prescribed EMC limits. In this case, a conformity assessment must be carried out by the customer.</li></ul>

## 8.2 Installing electrical protective devices

Protective devices that are prescribed by national regulations must be installed on site. This safety equipment is to be provided by the customer.

As a rule, the following protective devices must be installed:

- › Residual current device (RCD)
- › Circuit-breaker
- › Lockable 2-pole main switch acc. to EN 60947-3.

## 8.3 Connecting the mains cable



### IMPORTANT!

The wire cross-section of the mains cable must be between 1.5 and 4 mm<sup>2</sup>. Observe national provisions on line length and associated line cross-section.

### Prerequisites

- › The housing is open. ↗ Page 58, chapter 7.11

Disconnect the system from the power supply. Ensure that the system is powered down. Secure against reactivation. ⚠ DANGER  
Mortal danger by electric voltage!

3. Strip mains cable and strands according to the following figure.

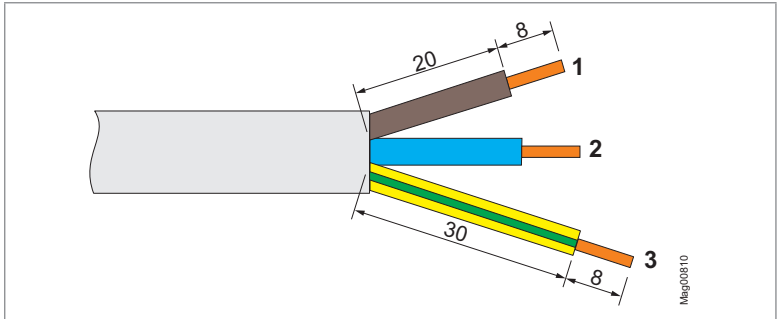

Fig. 30: Stripping (dimensions in mm)

- 1 Phase
  - 2 Zero conductor
  - 3 Protective earth conductor
4. Carefully lead the mains cable through the housing to the connection compartment and fasten it with the brackets.
  5. Connect the mains cable to the terminals X1: Connect L / N / PE. ↗ Wiring diagram, separate document.
  6. Attach mains cable to the tabs with 2 cable ties.

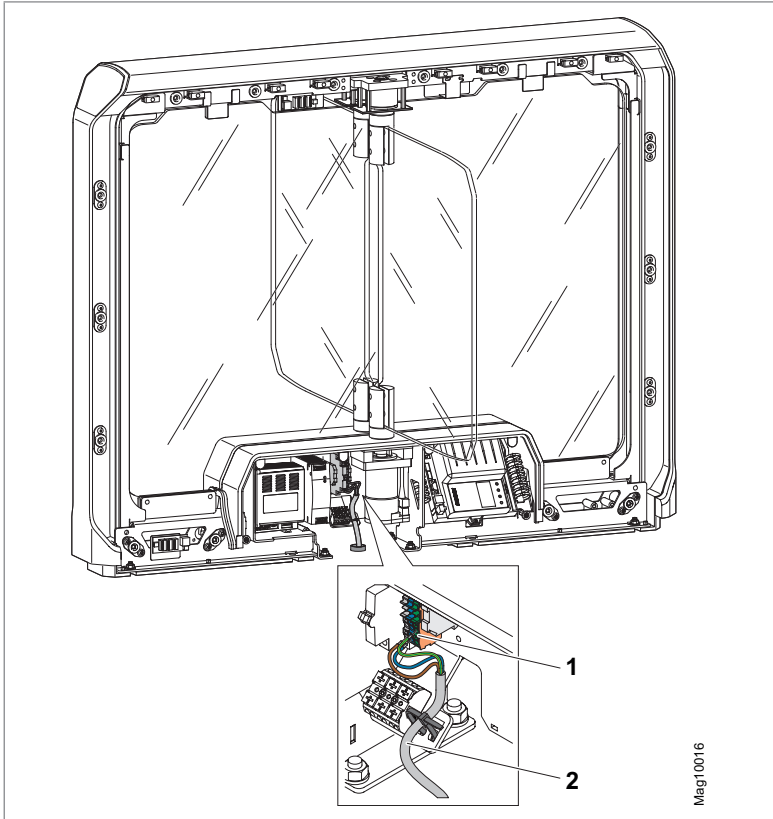

Fig. 31: Placing and connecting the mains cable

- 1 Terminals
- 2 Mains cable to be connected

## 8.4 Connecting customer control lines



**IMPORTANT!**

For connecting the control lines provided by the customer, see separate document "Description of MGCplus control unit for mWing (Doc.ID: 5817,0033)".

### 8.4.1 Connecting emergency opening contacts

↗ Separate wiring diagram and document "Description control unit MGCplus for mWing (Doc.ID: 5817,0033)".

Connect fire brigade switches, emergency opening contacts, etc. to the "Emergency open" input. This input has the highest priority. The "Emergency open" input function is superior to all other input functions. As long as +24 V DC are present at this input, the pedestrian gate is in operation.

## 8.5 Installing and connecting customer-access control devices

You can install access-control devices in the following locations:

› At both ends of the housing

↗ Separate wiring diagram and document "Description control unit MGCplus for mWing (Doc.ID: 5817,0033)".

### At both ends of the housing

Attach the access-control device to the cover with screws. Observe the installation dimensions.

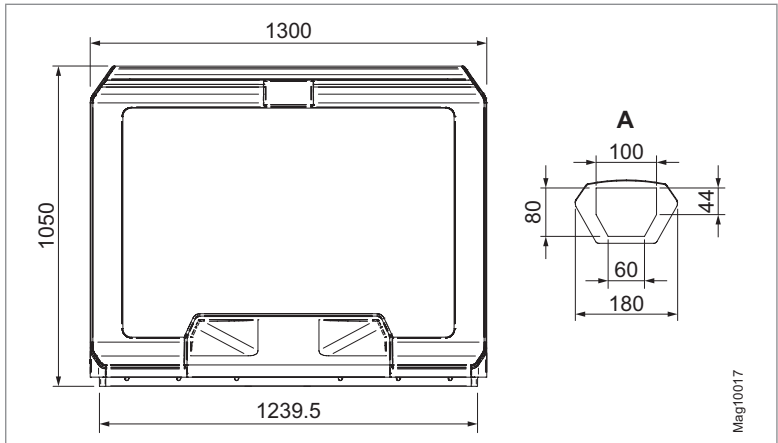

Fig. 32: Installation space for access-control device (dimensions in mm)

A Dimensions for customer's access-control device

## **8.6 Checking the electrical connections**

After the electrical installation, check the following points:

- › Does the power supply match the specification on the type plate?
- › Are the prescribed protective devices installed?
- › Is the pedestrian gate connected according to electrical circuit diagram?
- › Is the emergency signal transmitter correctly connected?
- › Are the customer's signal transmitters and receivers correctly connected?
- › Are all screws firmly tightened?
- › Have all pedestrian gate covers been properly assembled?



## 9 Commissioning

### 9.1 Safety during commissioning

#### Qualification of personnel

- › Magnetic MHTM™ FlowMotion® service expert
- ↗ Page 12, chapter 2.3.2.

#### Personal protective equipment

Wear the following personal protective equipment:

- › Work clothes
- › Protective gloves
- › Safety shoes.

### 9.2 Putting the pedestrian gate into operation



#### IMPORTANT!

Commissioning must be carried out in accordance with the test book. See separate document "Test Book mWing (Doc.ID: 5837,0011)".

### 9.3 Switching the pedestrian gate on and off

#### NOTICE



#### Fast restart!

Switching the pedestrian gate on again too fast can lead to damage to the device!

- › Wait for at least 10 seconds after switching off the pedestrian gate before you switch the mains power on again.

1. Install cover. ↗ Page 57, chapter 7.10.
2. Switch the pedestrian gate on or off using the on/off switch.

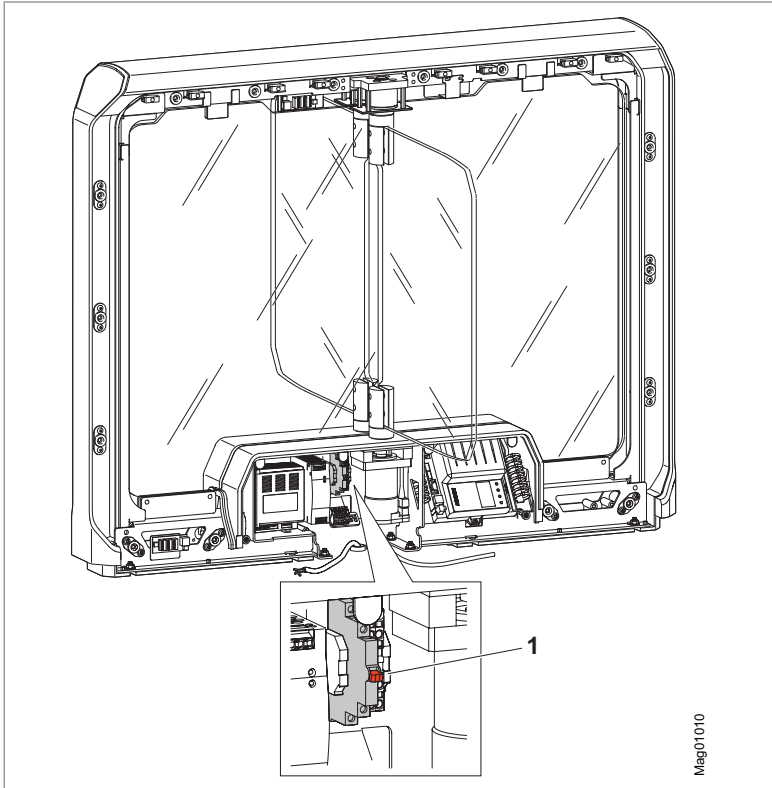

Fig. 33: Switching the mWing on and off

- 1 On and off switch

3. Assemble cover. ↗ Page 57, chapter 7.10.

## 9.4 Parameterising the pedestrian gate

### WARNING



#### Parameterisation by unqualified persons!

Parameterisation by unqualified persons may cause the swing doors to show unexpected behaviour.

- › Only Magnetic MHTM™ FlowMotion® service experts must set parameters.



#### IMPORTANT!

For parameterisation see separate document "Description of MGC control unit for mWing (Doc.ID: 5817,0033)".

## 10 Test book

The pedestrian gate must be checked at least once a year in accordance with the test book.

The "Test Book mWing" (Doc.ID: 5837.0011) is included in the scope of delivery.

## 11 Operation

The operation of the pedestrian gate depends on the connected access-control devices, signal transmitters and signal receivers as well as on the parameterisation of the control unit.

We recommend to create a description for the operation, depending on the connected devices and the parameterisation.



**IMPORTANT!**

For parameterisation see separate document "Description of MGC control unit for mWing (Doc.ID: 5817,0033)".

---

## 12 Cleaning and maintenance

### 12.1 Cleaning the pedestrian gate

NOTICE	
	<p><b>Aggressive cleaning aids and substances!</b></p> <p>Aggressive detergents and consumables may damage or destroy components, electric cables, or the coating of the pedestrian gate.</p> <p>› Do not use cleaning agents with aggressive ingredients.</p>

#### Cleaning the pedestrian gate from the outside

1. Switch off the power supply and secure against being switched on again.
2. Pre-clean surfaces with a damp cloth. Never use wet cleaning cloths.
3. Clean the surface with a mild household cleaner.
4. Carefully clean areas with persistent dirt with spirit.
5. Dry surfaces with a dry cloth.

### 12.2 Maintenance schedule

The maintenance plan lists all work required to ensure safe, optimum and trouble-free operation of the pedestrian gate.

Interval	Work	Personnel
Monthly	Check emergency function.	Operator
	Check the swing door and the inlay for damage from the outside.	Operator
Every 6 months	Check the attachment of the swing door.	Technician
	Check function of the external residual current operated device.	Technician
Every 12 months	Check electrical lines for damage.	Technician
	Check if all electrical connections are firm.	Technician
	Check the fastening of the housing.	Technician

Table 10: Maintenance schedule

### 13 Corrective action



**IMPORTANT!**

For troubleshooting, see separate document "Description of MGC control unit for mWing (Doc.ID: 5817,0033)".

---

### 14 Spare parts and repair

**NOTICE**



**Wrong and faulty spare parts!**

Incorrect or defective spare parts can result in damage, malfunctions or total failure and also impair safety.

› Use only the manufacturer's original spare parts.

Spare parts are available from your authorised dealer. The address can be found on your delivery receipt, invoice or the rear of these operating instructions.

Spare part lists can be obtained on request.

### 15 Customer service

Our customer service can be contacted for any technical advice. Notices concerning the responsible contact person can be retrieved by telephone, fax, E-mail or via the Internet at any time, refer to manufacturer's address on page 2.



**IMPORTANT!**

In order to enable fast handling note the data of the type plate such as type, serial number, version etc. before calling.

---

## 16 Decommissioning

You disable the pedestrian gate in the following cases:

- › The pedestrian gate is installed at a different location.
- › The pedestrian gate will be decommissioned for more than 6 months.

If you only want to deactivate the pedestrian gate for a short time, see the "Switching the pedestrian gate on and off" section. ↗ Page 65, chapter 9.3.

### 16.1 Safety during decommissioning

#### Qualification of personnel

- › Technician
- › Magnetic MHTM™ FlowMotion® service expert

↗ Page 12, chapter 2.3.2.

#### Personal protective equipment

Wear the following personal protective equipment:

- › Work clothes
- › Protective gloves
- › Safety shoes.

### 16.2 Take the pedestrian gate out of operation

1. Switch off the pedestrian gate. ↗ Page 65, chapter 9.3.
2. Disconnect the pedestrian gate from the power supply.
3. If necessary, dismantle the pedestrian gate.
4. Store pedestrian gate or components properly. ↗ Page 28, chapter 5.4.

## **17 Disassembly and disposal**

### **17.1 Safety during disassembly and disposal**

#### **Qualification of personnel**

- › Technician
- › Electrical specialist
- › Magnetic MHTM™ FlowMotion® service expert
- ↗ Page 12, chapter 2.3.2.

#### **Personal protective equipment**

Wear the following personal protective equipment:

- › Work clothes
- › Protective gloves
- › Safety shoes.

### **17.2 Dismantling and disposing of the pedestrian gate**

#### **Prerequisites**

- › The pedestrian gate is out of order. ↗ Page 71, chapter 16.2.
1. Disassemble the pedestrian gate into individual parts.
  2. Recycle parts by type and material. Dispose of non-recyclable materials in an environmentally friendly manner. Observe local and national laws and guidelines.
- ✓ The pedestrian gate is disassembled and disposed of.



# EU-Declaration of Conformity



The manufacturer MAGNETIC AUTOCONTROL GmbH hereby declares for the product supplied by him:

Designation	<b>Pedestrian gate FlowMotion®</b>
Type	mWing FMWI_*
From serial number	11070769

The conformity according to:

**Directive 2006/42/EC** (Machinery Directive) amended by **2009/127/EC**

**Directive 2014/30/EU** (EMC Directive)

**Directive 2011/65/EU** (RoHS Directive)

Applied harmonised standards (or parts hereof):

**EN ISO 12100:2010**

Safety of machinery – General principles for design – Risk assessment and risk reduction

**EN 60204-1:2006/AC:2010**

Safety of machinery – Electrical equipment of machines – Part 1: General Requirements

**EN 61000-6-2:2005/AC:2005**

Electromagnetic compatibility (EMC) – Part 6-2: Generic standard – Immunity for industrial environments

**EN 61000-6-3:2007/A1:2011/AC:2012**

Electromagnetic compatibility (EMC) – Part 6-3: Generic standard – Emission standard for residential, commercial and light industry

**EN ISO 13849-1:2008/AC:2009**

Safety of machinery – Safety-related parts of control systems – Part 1: General principles of design

**EN 60335-2-103:2015**

Household and similar electrical appliances – Safety - Part 2-103: Particular requirements for drives for gates, doors and windows

**prEN17352:2019**

Force-actuated access control devices – usage safety – requirements and test methods

This declaration is not an assurance of properties within the meaning of the Product Liability Act. The safety information of the operating instructions must be observed.

MAGNETIC AUTOCONTROL GmbH  
Griematt 20-28  
D-79650 Schopfheim

Authorized for documentation  
Mr Stefan Wellinger

Schopfheim, December 2019

Place and date

Signature



## Index

### A

Access-control devices	
Assembly .....	63
Connecting .....	63
Assembly .....	33, 42
Cover .....	58
mWing .....	53
Testing .....	58

### C

Changes .....	10
Cleaning .....	69
Clearances	
Min. ....	17
Commissioning .....	65
Connection. See Electrical connection	
Control lines	
Connecting .....	62
Control unit MGCplus .....	20
Technical data .....	19
Corrective action .....	70
Cover .....	20
Customer service .....	70

### D

Decommissioning .....	71
Design .....	20
Disassembly .....	72
Cover .....	57
Disposal .....	72

### E

Electrical connection .....	59
Technical data .....	18
Testing .....	64
Emergency opening .....	63
Emissions .....	18
Empty conduits	
Requirements .....	35
EU-Declaration of Conformity .....	73

### F

Foundation	
Requirements .....	35
Set up .....	36

### G

Goods receiving department .....	26
----------------------------------	----

### I

Installation .....	33
Intended use .....	10

### L

Line configuration .....	17
--------------------------	----

### M

Magnetic MHTM™ FlowMotion® service expert .....	12
Mains cable	
Connecting .....	61
Maintenance schedule .....	69
Misapplications .....	10
Modifications .....	10
Mounting variants .....	34
Direct mounting .....	42
Glueing the base plate .....	49
Mounting the base plate .....	45

### N

Notices	
Presentation .....	8

### O

Operating conditions .....	18
Operation .....	68
Operator	
Responsibility .....	11

### P

Parameterise .....	67
Personal protective equipment .....	13
Personnel	
Qualification .....	12

**Q**

Qualification  
Personnel..... 12

**R**

Repair ..... 70

**S**

Safety..... 10  
Safety guards  
Install ..... 60  
Scope of delivery ..... 30  
Spare parts ..... 70  
Storage ..... 28  
Switching off..... 65  
Switching on ..... 65

**T**

Target groups..... 11  
Technical data ..... 16  
Test book ..... 67  
Transport ..... 27  
Type plate..... 32

**U**

Unpacking..... 29

**W**

Warning Notes  
Presentation ..... 8







---

**MAGNETIC AUTOCONTROL GMBH**

Grienmatt 20  
D-79650 Schopfheim  
Germany

Sales partner

Phone +49 7622 695 5  
Fax +49 7622 695 802  
info@magnetic-germany.com  
www.magnetic-access.com



F10044454

Doc.ID: 58170034EN  
Version 00