

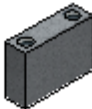











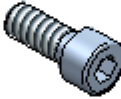











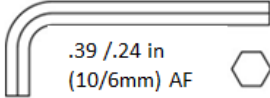

MHTM™ MicroDrive

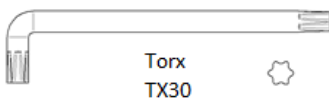
**Articulated boom  
KBS/KBB**

Pos.	part name		Pos.	part name	
1	hinge		45	threated plate	
30	case		46	screw	 DIN7500E M6 x 30 Torx
31	holding sheet		47	screw	 10x DIN912 M8 x 20
32	end piece RH		48	screw	 DIN931 M12 x 45
33	end piece LH		49	washer	 DIN125 A13
40	rod end RH		50	SCHNORR® washer	 M6
41	rod end LH		51	SCHNORR® washer	 10x M8
42	nut	 DIN439 M12 LH	70	alu-profile	
44	nut	 DIN985 M12	71	edge protection	
43	nut	 DIN985 M12			

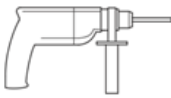
### Tools

 .39 / .24 in (10/6mm) AF 	 Torx TX30 		.71 in (18mm) DIN .75 in (19mm) ISO
			.35 in (9,0mm)
	BSKBB (optional)		5675,5001 calculation tool

(1)

	<b>.35 in (9mm)</b>			<b>BSKBB (optional)</b>		<b>5675,5001</b>
---	---------------------	---	---	-------------------------	--	------------------

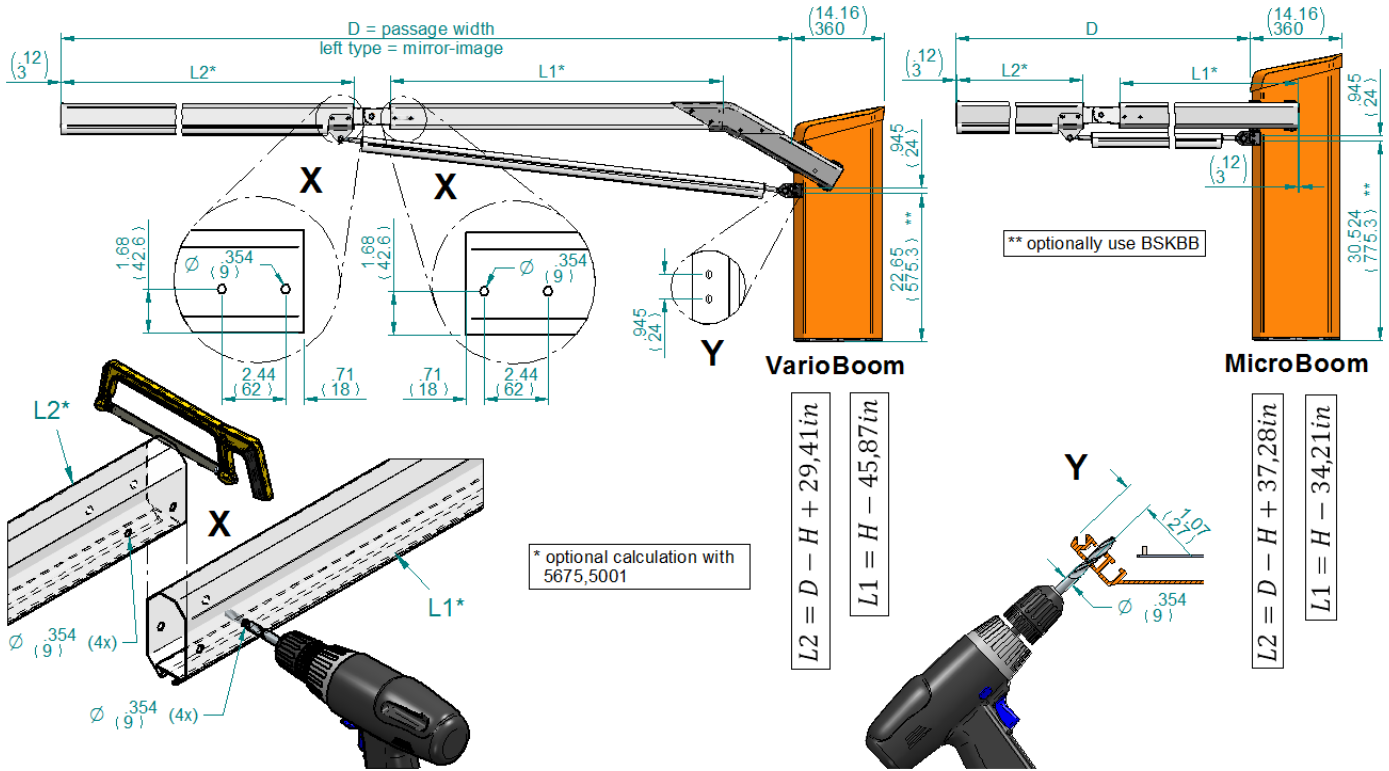

(2)

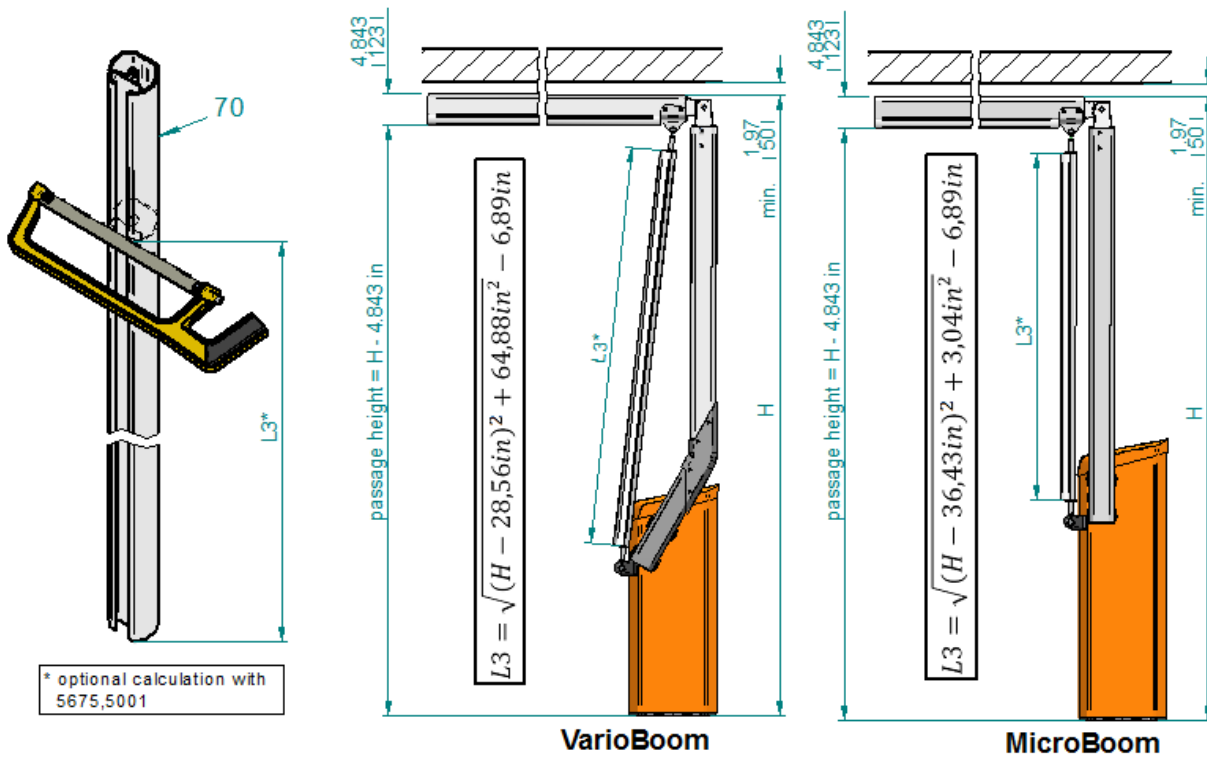
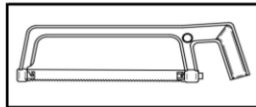

**(3)**

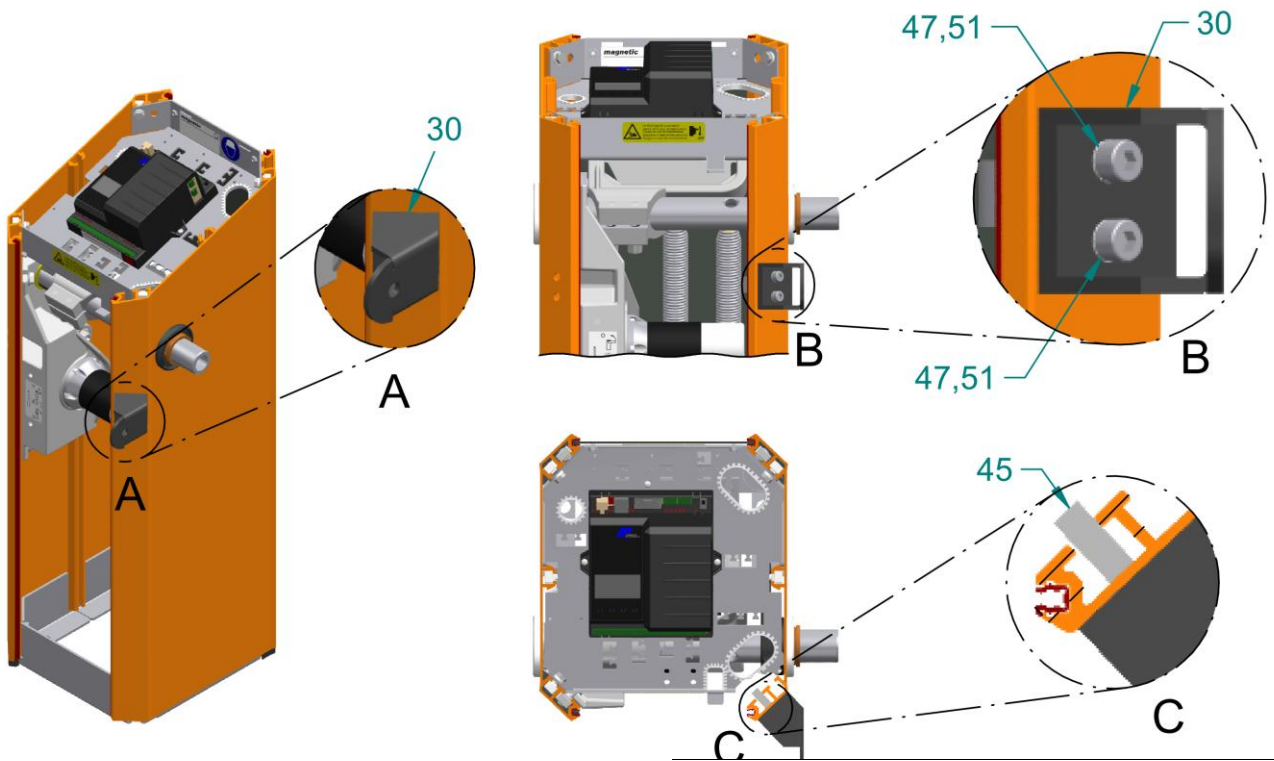
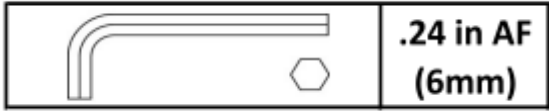

**(4)**

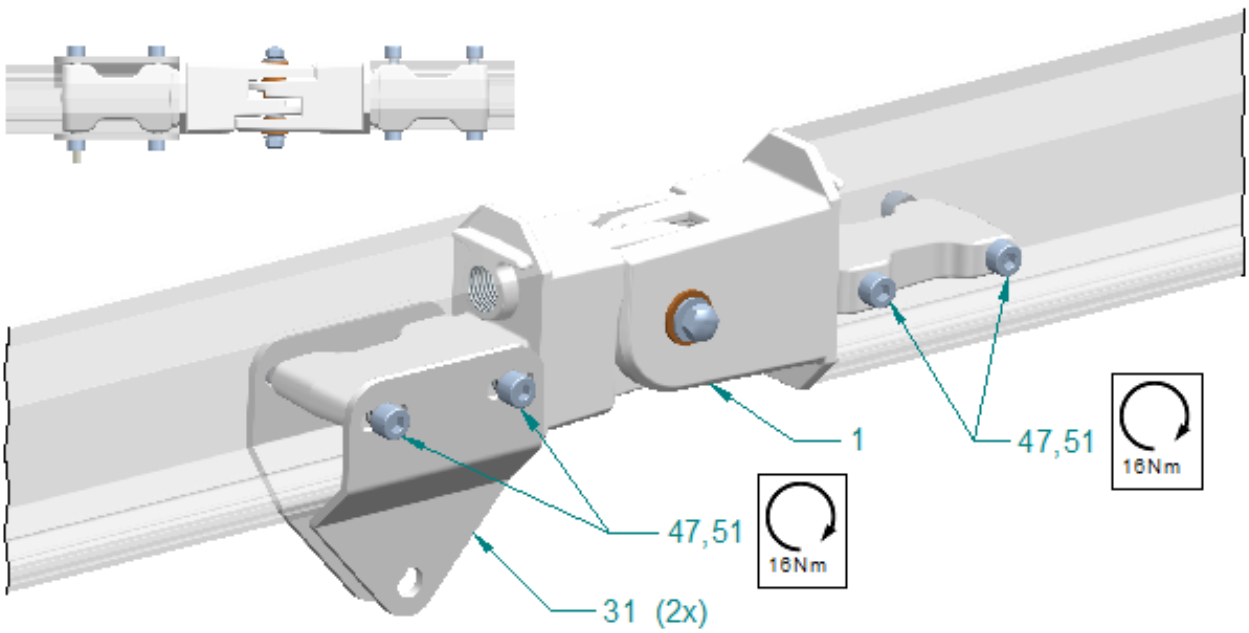

**(5)**



**Torx TX30**



**.71 in (18mm) DIN /  
.75 in (19mm) ISO**

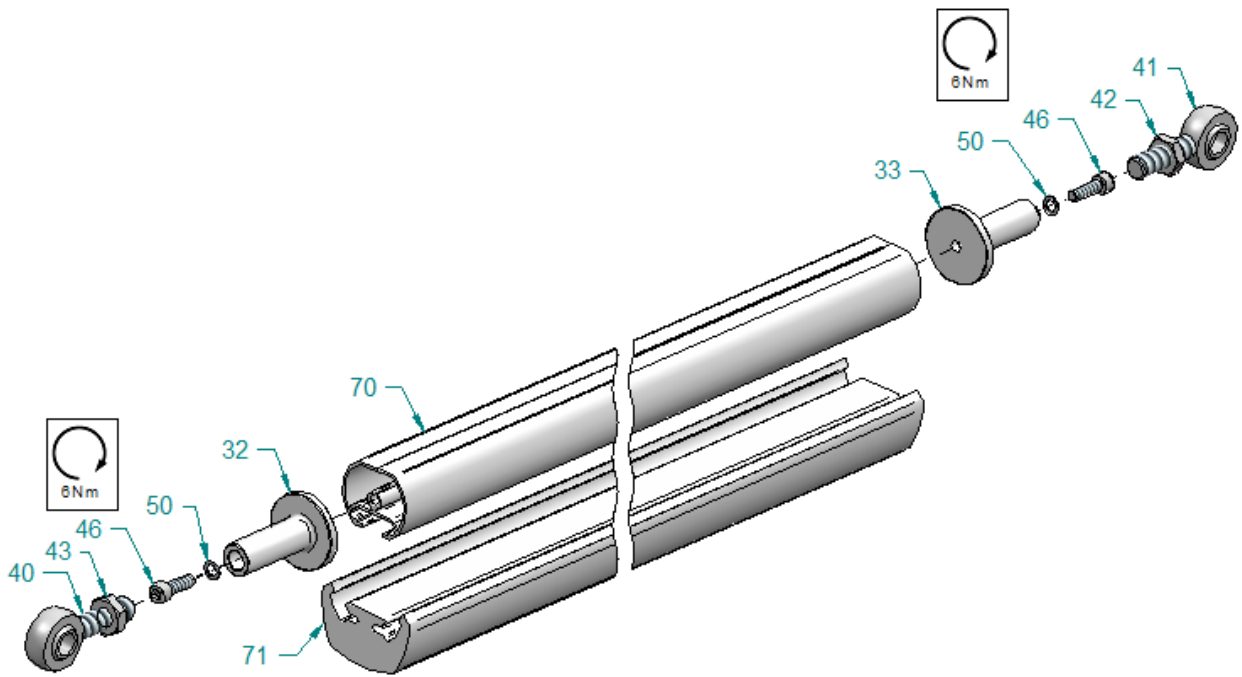

**(6)**



**.71 in (18mm) DIN /  
.75 in (19mm) ISO**

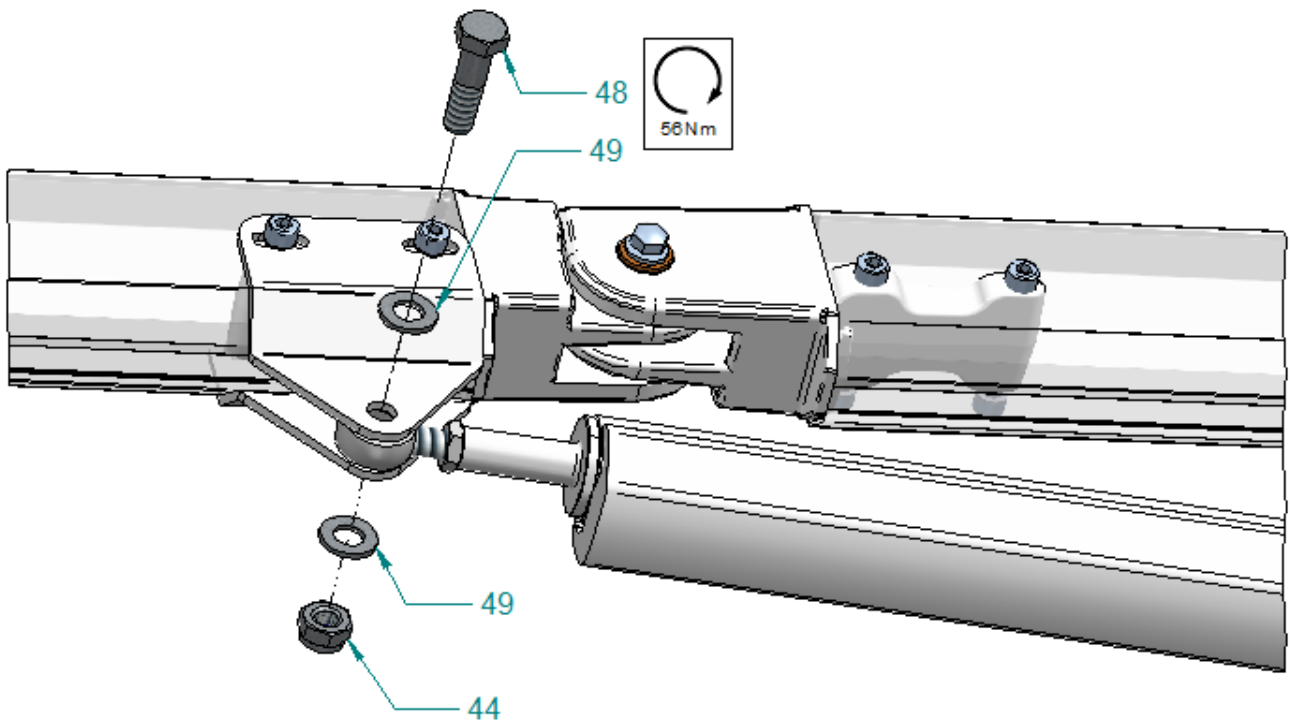

**(7)**

	<b>.39 in AF (10mm)</b>		<b>.71 in (18mm) DIN / .75 in (19mm) ISO</b>
---	-----------------------------	---	--

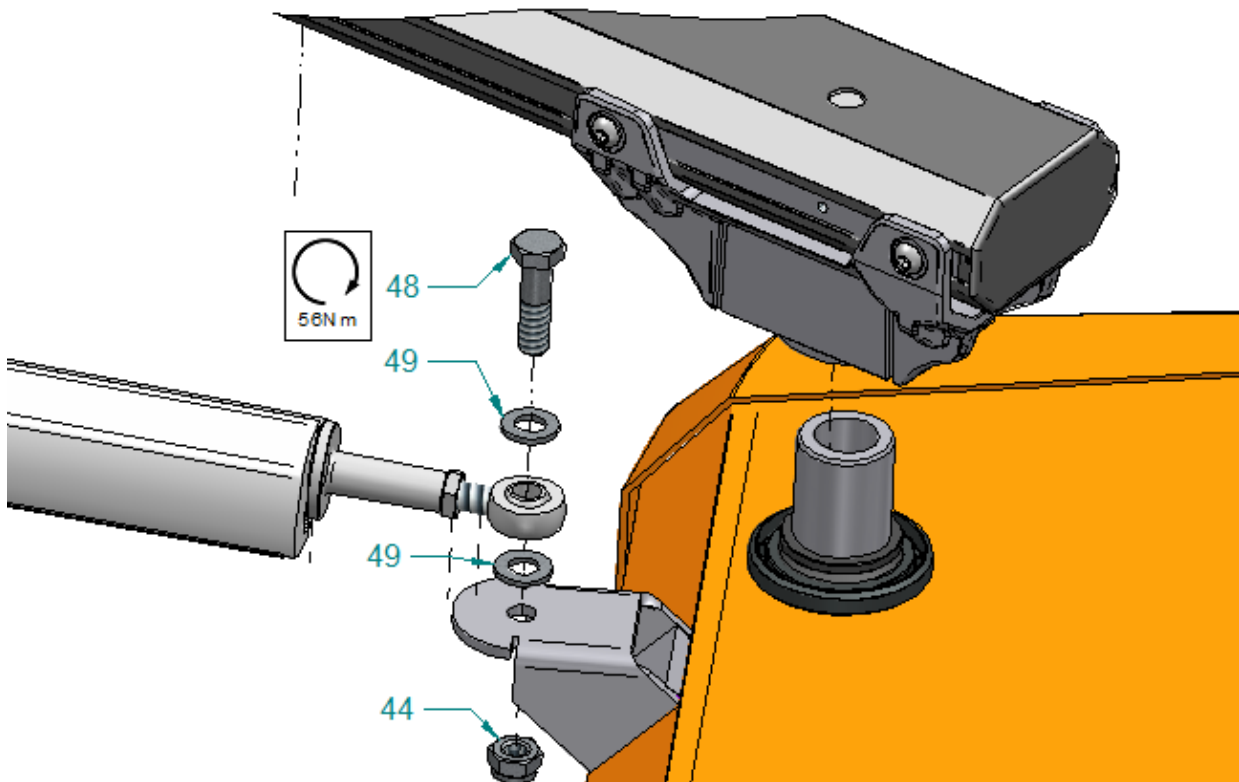

**(8)**

	<b>.39 in AF (10mm)</b>
---	-----------------------------

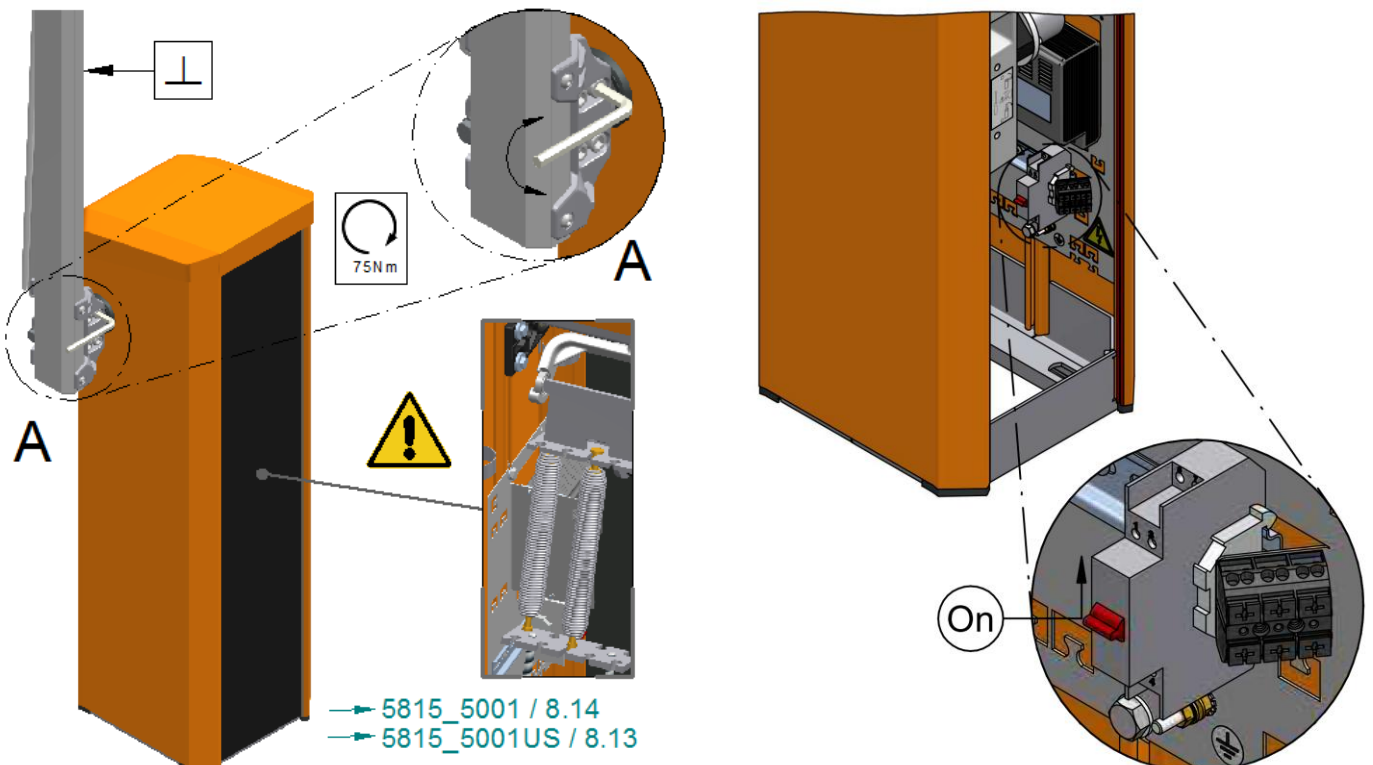

**(9)**

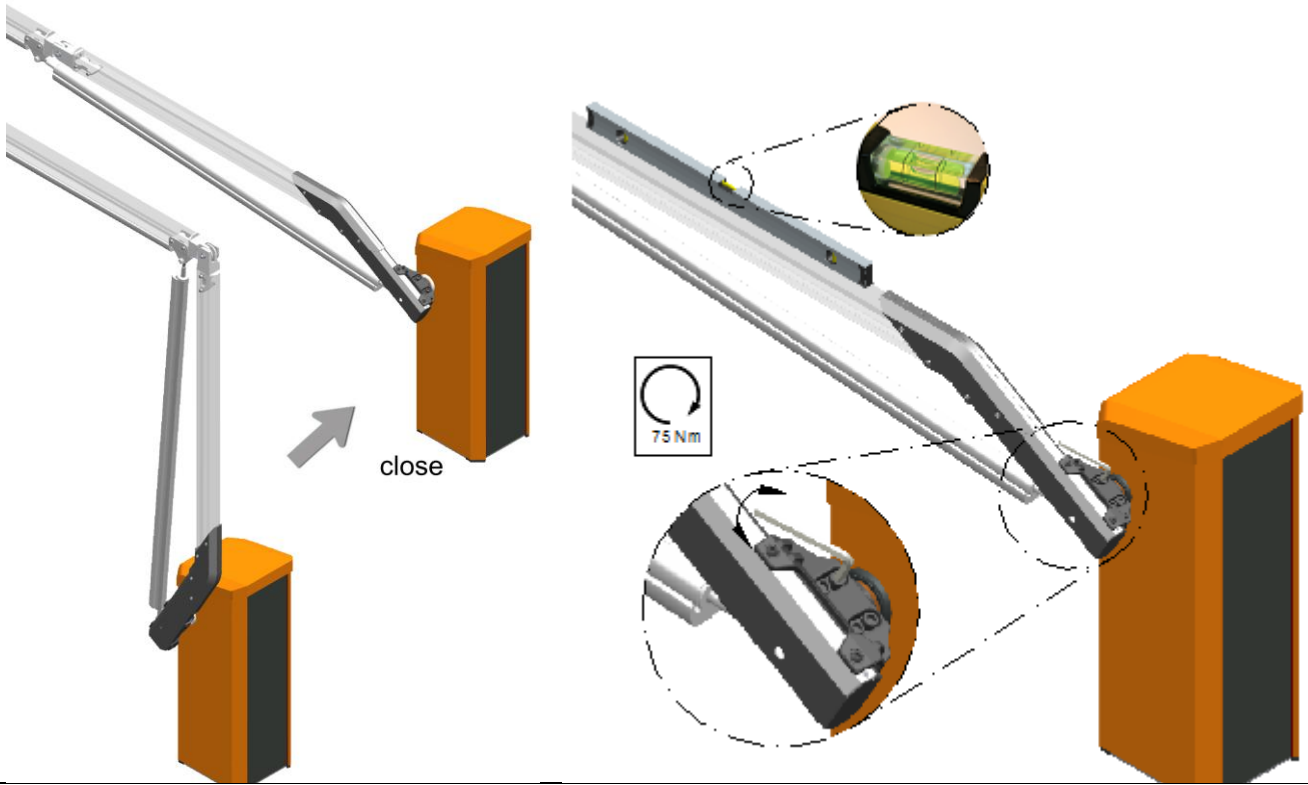
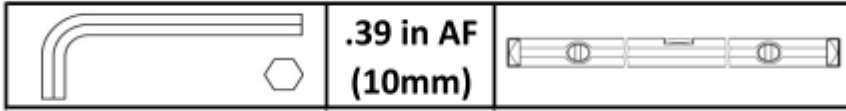

**(10)**

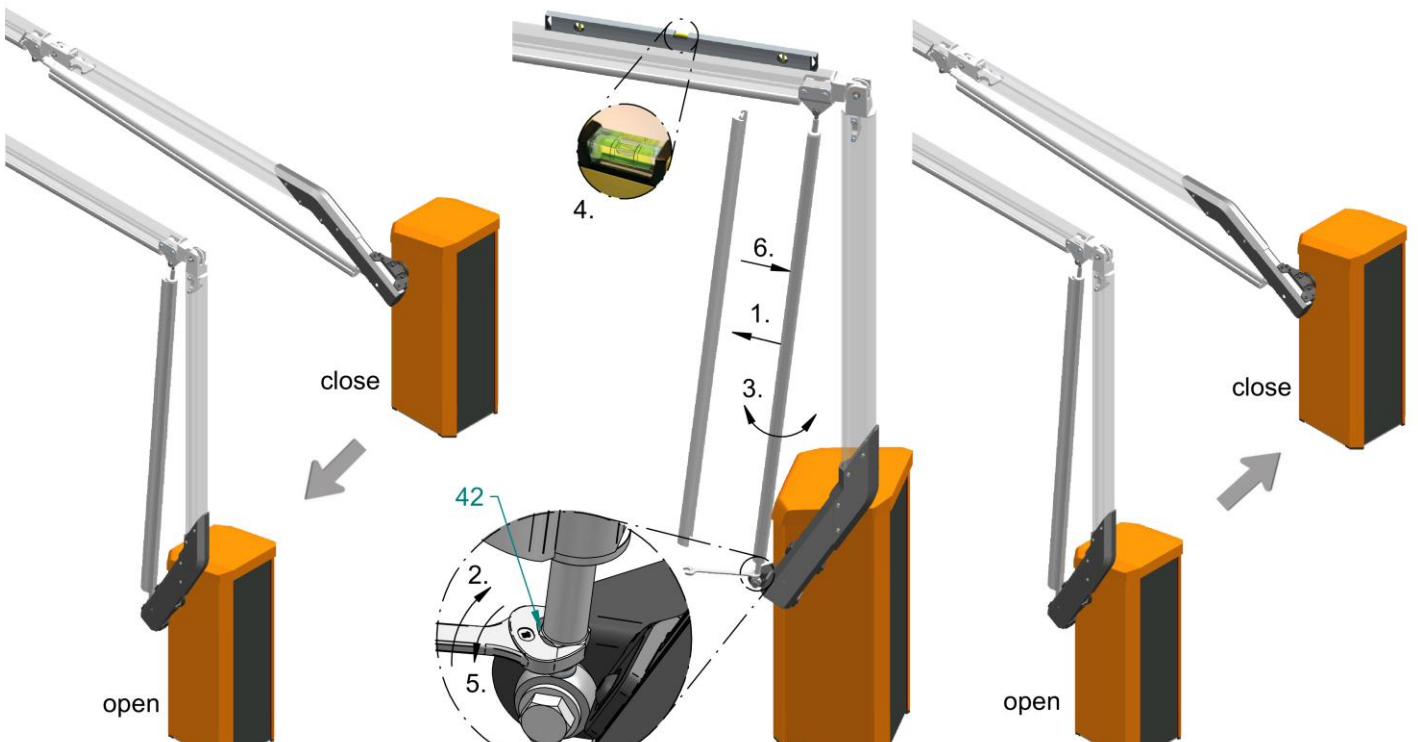

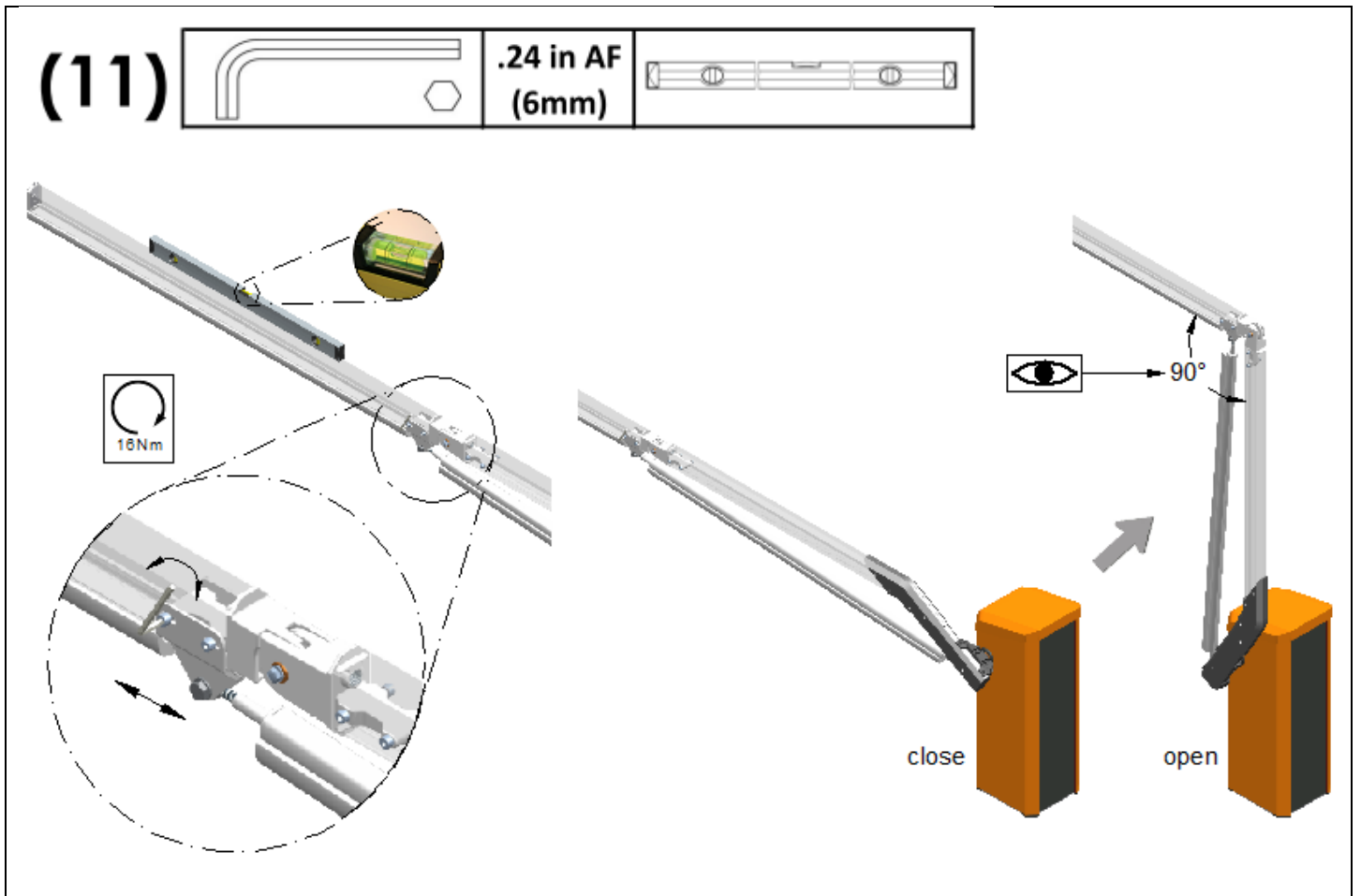

MAGNETIC Autocontrol GmbH  
 Grienmatt 20  
 79650 Schopfheim  
 Deutschland  
 Tel.: +49 (0) 7622 695 5  
 Fax.: +49 (0) 7622 695 602  
[info@ac-magnetic.com](mailto:info@ac-magnetic.com)  
[www.ac-magnetic.com](http://www.ac-magnetic.com)

MAGNETIC Automation Corporation  
 3160 Murrell Road  
 Rockledge, Florida, 32955  
 USA  
 Phone: +1 321 635 8585  
 Fax.: +1 321 635 9449  
[info@ac-magnetic-usa.com](mailto:info@ac-magnetic-usa.com)